

## advanced FLOW engineering

### Instruction Manual P/N: TR-1020B



Make: **Honda** Model: **Civic** Year: **2012-2015** Engine: **L4-1.8L**

Make: **Acura** Model: **ILX** Year: **2013-2015** Engine: **L4-2.0L**



- Please read the entire instruction manual before proceeding.
- Ensure all components listed are present.
- If you are missing any of the components, call customer support at 951-493-7100.
- Ensure you have all necessary tools before proceeding.
- Do not attempt to work on your vehicle when the engine is hot.
- Disconnect the negative battery terminal before proceeding.
- Retain factory parts for future use.

Label	Qty.	Description	Part Number
A	1	Air Filter (Pro 5R)	TF-9020R (Blue Media)
B	1	Tube	05-T1020B1
C	2	Clamp, 044	03-50019
D	1	Coupling Silicone	05-01188
E	1	Grommet	03-50033

Installation will require the following tools:  
Phillips screw driver, 8mm nut driver, ratchet, extension, 10mm socket & pliers

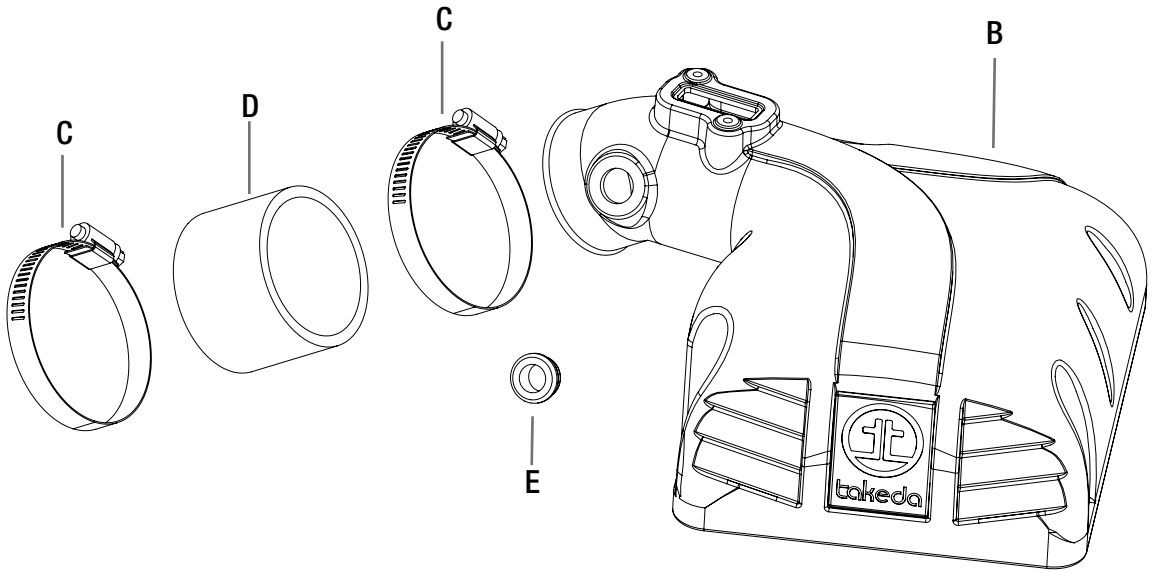



**Refer to Figure A for step 1-7**

- Step 1: Remove the inlet duct coupling connecting the OE air box to the air resonator tube. (1).
- Step 2: Disconnect the crank case line from the OE tube (2).
- Step 3: Loosen the clamp connecting the OE tube to the throttle body (3).
- Step 4: Remove the two bolts holding the OE air box (4).
- Step 5: Disconnect the MAF sensor and harness off the OE air box (5).
- Step 6: Pull off the OE air box off the grommet.
- Step 7: Remove the complete OE air box out of the vehicle.



Figure B

**Refer to Figure B for step 8**

Step 8: Install the supplied coupling with clamps onto the throttle body ⑥.



**Figure C****Refer to Figure C for steps 9-10**

Step 9: Remove the MAF sensor off the OE air box and install onto the new Takeda tube/housing using the OE screws and gasket. Then install the supplied grommet into the hole (7).

Step 10: Install the Takeda filter onto the Takeda tube/housing and tighten the clamp (8).



Figure D

**Refer to Figure D for steps 11-15**

Step 11: Place the Takeda housing onto the bottom half of the OE air box and install onto the vehicle.

Step 12: Re-connect the MAF sensor and re-install the crank case line into the grommet ⑨.

Step 13: Secure the air box assembly with the bolts removed in step 4.

Step 14: Clip all 3 factory clips to secure the Takeda tube/housing onto the OE air box.

Step 15: Re-install the coupling connecting the resonator tube to the housing ⑩.

Step 16: Tighten all clamps and bolts. Your installation is now complete. Thank you for choosing Takeda!

**NOTE: Retighten all connections after approximately 100-200 miles.**

**Place enclosed CARB EO sticker on or near the device on a smooth, clean surface.**

**EO identification label is required to pass the smog inspection.**



Page left blank intentionally



Page left blank intentionally

Pro DRY S Air Filter



P/N: TF-9020D

Pro 5R Air Filter



P/N: TF-9020R

Pro DRY S Restore Kit



P/N: TP-7015C

Takeda Tee



P/N: TP-7004T M  
P/N: TP-7005T L  
P/N: TP-7006T XL  
P/N: TP-7007T 2XL

Key Chain

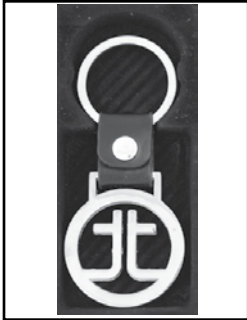

P/N: TP-7018K

Key Chain



P/N: TP-7024K

Mascot Decal

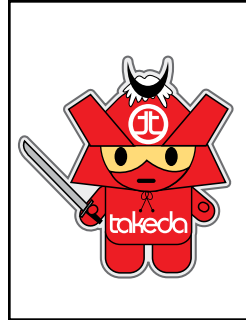

P/N: TP-7003D

Lic. Plate Frame



P/N: TP-7014F

To purchase any of the items above, view airflow charts, dyno graphs, photos, and video; please go to [aFepower.com](http://aFepower.com).

# Warranty

## General Terms:

- aFe warrants their products to be free from manufacturer's defects due to workmanship and material.
- This warranty applies only to the original purchaser of the product and is non-transferrable.
- Proof of purchase of the aFe product is required for all warranty claims.
- Warranty is valid provided aFe instructions for installation and/or cleaning were properly followed.
- Proper maintenance with regular inspections of product is required to insure warranty coverage.
- Damage due to improper installation, abuse, unauthorized repair or alteration is not warranted.
- Incidental or consequential damages or cost, including installation and removal of part, incurred due to failure of aFe product is not covered under this warranty.
- All warranty is limited to the repair and/or replacement of the aFe part. To request Return Goods Authorization ("RGA"), email [RGA@afepower.com](mailto:RGA@afepower.com) or call (951)493-7100. Upon receipt of the RGA, you must return the product to the address provided in the RGA, freight prepaid and accompanied with a dated proof of purchase and the RGA. Upon receipt of the defective product and upon verification of proof of purchase, aFe will either repair or replace the defective product within a reasonable time, not to exceed thirty days.

Product Category	P/N Prefix	Warranty duration
Direct OE Replacement Filters	10, 11, 30, 31, 71, 73	Life of the vehicle
Racing Filters	18	1 year
Universal	21, 24, 72,TF	2 years
Air Intake Systems	50, 51, 54, 55, 75,TR,TA,TL	2 years
Exhaust Systems	49	2 years
Intercoolers & Intercooler Tubes	46-2	2 years
Intake Manifolds	46-1	2 years
Differential Cover	46-7	Life of the vehicle
Exhaust Manifolds	46	2 years
Throttle Body Spacers	46-3	2 years
Turbochargers	46-6	2 years*
Fluid Filters	44	90 days
Pre-Filters	28	2 years
Heavy Duty OE Replacement	70	2 years
PowerSports OE Replacement	81, 87	2 years
PowerSports Intake Systems	85	2 years

No other warranty expressed or implied applies nor is any person or advanced FLOW engineering authorized to assume any other warranty. Some States do not allow the exclusion or limitation of incidental or consequential damages or do not allow limitations on how long an implied warranty lasts, so the above limitations or exclusions may not apply to you. This warranty gives you specific legal rights, and you may also have other rights which vary from State to State.

\*See turbocharger warranty for more info



**advanced FLOW engineering, inc.**

252 Granite Street Corona, CA 92879

TEL: 951.493.7100 • TECH: 951.493.7100

E-Mail: [Tech@aFepower.com](mailto:Tech@aFepower.com)