

advanced FLOW engineering

Cold Air Intake System

Instruction Manual P/N: 52-10015D / 52-10015R

Make: FORD	Model: Expedition	Year: 2022-2024	Engine: V6-3.5L(tt)
Make: FORD	Model: F-150	Year: 2021-2024	Engine: V6-3.5L(tt)
Make: FORD	Model: F-150 Raptor	Year: 2021-2024	Engine: V6-3.5L(tt)
Make: Lincoln	Model: Navigator	Year: 2022-2024	Engine: V6-3.5L(tt)



- Please read the entire instruction manual before proceeding.
- Ensure all components listed are present.
- If you are missing any of the components, call customer support at 951-493-7185.
- Ensure you have all necessary tools before proceeding.
- Do not attempt to work on your vehicle when the engine is hot.
- Retain factory parts for future use.

Label	Qty.	Description	Part Number
A1	2	Raw Part: 24-91117	24-91117
A2	2	Raw Part: 21-91117	21-91117
B	1	Tube #1 of 2: 54-12882-B (Wrinkle Black)	05-12882B1
C	1	Tube #2 of 2: 52-10015 (Wrinkle Black)	05-5210015B2
D	1	Housing: 52-10015	05-5210015B3
E	1	Cover: 52-10015	05-5210015B4
F	1	Coupling, Silicone Straight: 2.25"ID x 1.50"L	05-01453
G	1	Coupling, Sil Elbow Rdr: (3.50" x 3")ID x 40 Deg	05-01737
H	1	Coupling, Silicone Elbow Rdr: (4" x 3.50") 40 Deg	05-01447
J	1	Clamp, 064 (2.50"- 4.50 ")	03-50006
K	2	Clamp, 032 (1.56" -2.50")	03-50016
M	1	Clamp, 048 (2.56" – 3.50 ")	03-50007
N	2	Clamp, 056 (3.09" - 4 ")	03-50009
P	4	Screw, Btn Hd Socket: M6x1x12	03-50102
Q	1	Vent Insert	05-01405

Installation will require the following tools: 7mm, 8mm, 11mm and 13mm Nut Drivers or Ratchet and Sockets, Flat Head Screwdriver, 5/8" Quick disconnect tool*

*Only required if vehicle equipped with orange tab on quick disconnect fitting, see page 8-9.

Warranty Information available at: <https://afepower.com/contact#warranty>

Product covered by one or more of the following patents: 11125150, 11603792, 10648404

Emissions Disclaimer: This product is not currently CARB exempt and is not available for purchase in California or for use on any vehicle registered with the California Department of Motor Vehicles.

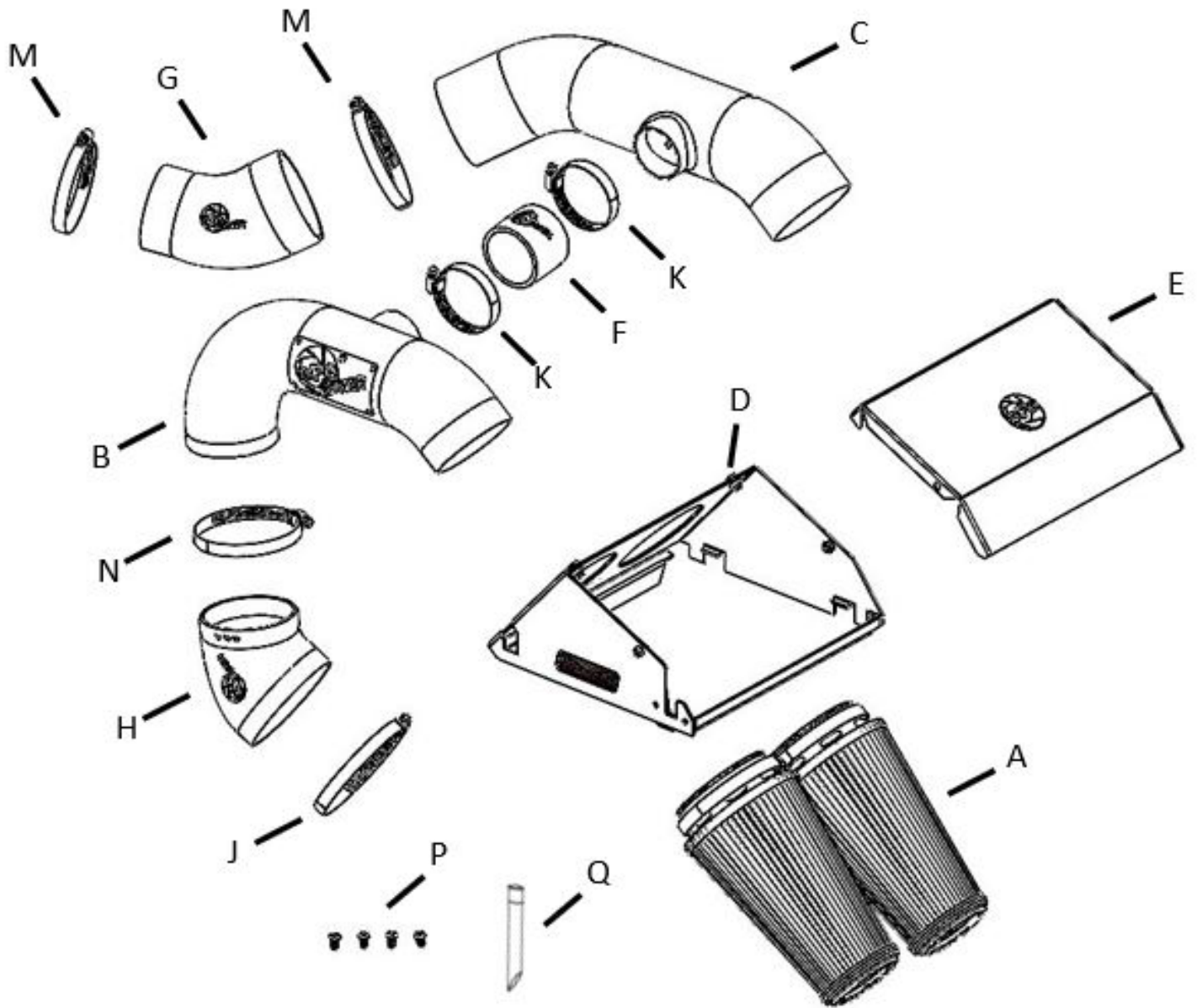

**Figure A****Refer to Figure A for Steps 1-4**

Step 1: Disconnect the Intake Air Temperature (IAT) Sensor (1).

Step 2: Loosen the two clamps securing the intake tube to the turbo inlets (2).

Step 3: Unclip the coolant hose from the intake tube (3).

Step 4: Unlatch the two clips securing the top of the air box, and then remove the intake tube and the top of the air box from the vehicle (4).



Figure B

Refer to Figure B for Steps 5-6

Step 5: Disconnect the IAT harness from the airbox (5.)

Step 6: Remove air filter from the air box.

REMOVE



Figure C

Refer to Figure C for Step 7



The installation of the plastic vent tube insert is important to prevent check engine light. These procedures should be done with the turbo inlet tubes installed on the engine. It is shown off the vehicle for better illustration.

Step 7: Locate the factory plastic tube feeding the driver's side turbo inlet. This is the connection closer to the turbo.

For additional help, check out the video on YouTube titled: aFe POWER F 150 EcoBoost Vent Insert Tube Tech Tip

Or follow the link: <https://www.youtube.com/watch?v=vhaYJGbtEW4> or QR code:





Refer to Figure D for Steps 8-9

Step 8: Locate the valve cover vent tube that feeds into the driver's side turbo inlet (the connection closer to the turbo). It is not necessary to remove the engine cover.

Step 9: Check the color of the locking tab on the quick disconnect fitting. If the locking tab is orange, go to steps 10 and 11. If the locking tab is blue or grey, go to step 12.



Refer to Figure E for Step 10

Step 10: If the locking tab of the quick disconnect fitting is orange, like in this picture, you will need a quick-disconnect tool to remove it. Those disconnect tools are commonly used on AC and fuel lines.



Figure F

Refer to Figure F for Step 11

Step 11: For the fitting with the orange locking tab, slide the 5/8" quick-disconnect tool over the fitting and push it inside of the fitting. Rotate it and pull on the fitting at the same time.

REMOVE



Figure G

Refer to Figure G for Step 12

Step 12: If the locking tab is grey or blue, apply pressure against the exposed tail and pull vent fitting off the turbo inlet tube. It is not necessary to disconnect at the valve cover end. There is a sensor and wire harness on this vent tube. Do not damage or remove these components.



Refer to Figure H for Step 13

Step13: Insert vent fitting with slash cut facing turbo. It should not be a loose fit. It is direction dependent and must not rotate once installed.

**Figure I****Refer to Figure I for Steps 14-15**

Step 14: Reconnect the vent fitting. It will snap over without having to release the plastic clip. Pull up slightly to confirm installation.

Step 15: Installation of the vent tube is complete. Any codes can be cleared with a code reader or by disconnecting the battery. You will lose any radio presets with battery disconnection.

If removal of the vent insert is required, it can be pulled out with internal snap ring pliers.

**Figure J****Refer to Figure J for Step 16**

Step 16: Firmly press the air filters into the aFe POWER housing (6), making sure the air filter tabs lock into place. Place the clamps over the flanges of the air filters. Do not tighten the clamps at this time.

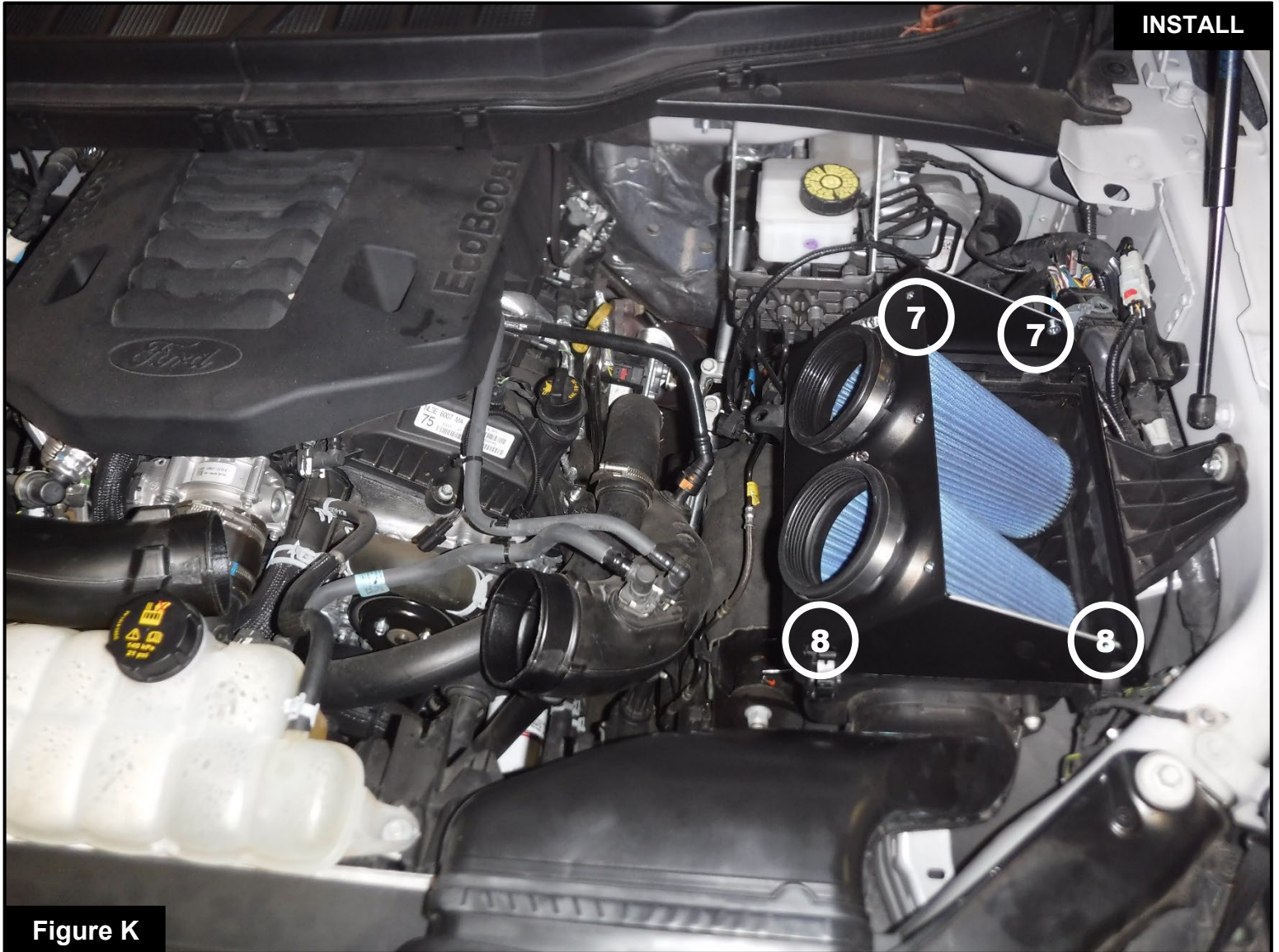
**Figure K****Refer to Figure K for Step 17**

Step 17: Install the aFe POWER housing with filters into the vehicle by sliding the tabs into the backside of the factory housing (7) then securing it with the factory locking tabs (8).

**Figure L**

Refer to Figure L for Step 18

Note: Be sure to lubricate the O-ring with grease to prevent it from tearing during installation.

Step 18: Transfer the IAT sensor from the factory intake tube to the rear aFe POWER intake tube (9) by gently lifting the locking tab with a screwdriver and twisting counter-clockwise to unlock it from the tube. Be sure the sensor locks into place on the aFe POWER intake tube.

**Figure M****Refer to Figure M for Step 19**

Step 19: Install the aFe POWER silicone reducer elbow 3.50" x 3" x 40Deg coupling and the rear aFe POWER Intake tube into the vehicle with one #48 clamp and one #56 clamp on the coupling (10)



Figure N

Refer to Figure N for Steps 20-22

Step 20: Install the aFe POWER silicone reducer elbow 4" x 3.50" x 40Deg coupling with one #56 clamp and one #64 clamp onto the driver's side turbo inlet (11) do not tighten the clamps yet.

Step 21: Install the aFe POWER silicone straight 2.25" x 1.50"L coupling with two #32 clamps onto the cross-over tube on the front aFe POWER intake tube (12) do not tighten the clamps yet.

Step 22: Install the front aFe POWER intake tube and adjust it so that it is parallel to the rear tube, then tighten all clamps (13).



Figure O

Refer to Figure O for Step 23-24

Step 23: Install the aFe POWER cover and secure with the four M6X1.0x12 screws (14)

Step 24: Verify that all clamps and connections are secured. Your installation is now complete. Thank you for choosing aFe POWER!



PAGE LEFT BLANK INTENTIONALLY



advanced FLOW engineering, inc.

Corona, CA 92879

afepower.com