

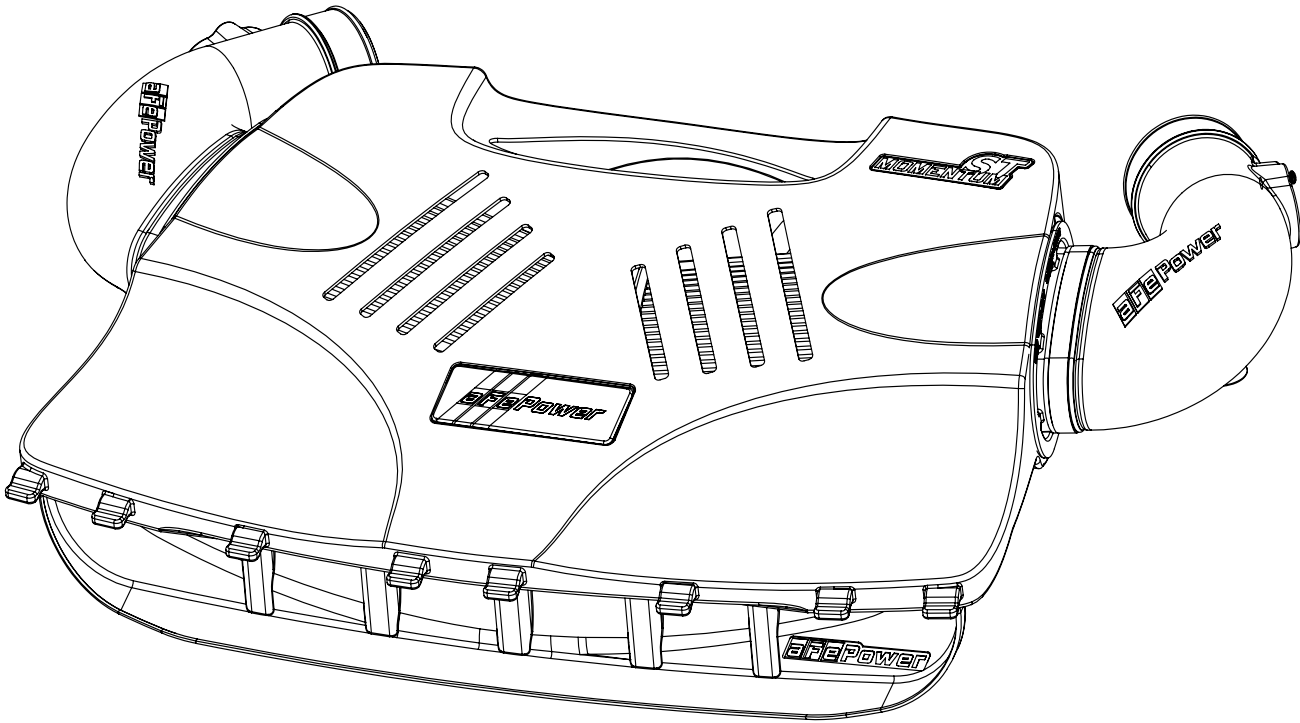

ST
MOMENTUM™



advanced FLOW engineering

Cold Air Intake System

Instruction Manual P/N: 50-40045D / 50-40045R

Make: BMW

Model: X5 M (F85)

Year: 2015-2018

Engine: V8-4.4L (tt) S63

Make: BMW

Model: X6 M (F86)

Year: 2015-2019

Engine: V8-4.4L (tt) S63



- Please read the entire instruction manual before proceeding.
- Ensure all components listed are present.
- If you are missing any of the components, call customer support at 951-493-7185.
- Ensure you have all necessary tools before proceeding.
- Do not attempt to work on your vehicle when the engine is hot.
- Disconnect the negative battery terminal before proceeding.
- Retain factory parts for future use.

Label	Qty.	Description	Part Number
A1	2	Air Filters (Pro DRY S)	21-90109
A2	2	Air Filters (Pro 5R)	24-90109
B	1	Tube, Driver Side	05-5040045B1
C	1	Tube, Passenger Side	05-5040045B2
D	1	Housing	05-5040045B3
E	3	Mount, Rubber: Housing	03-50534
F	2	Mount, Rubber: Tube	03-50620
G	4	Screw, Torx: M4	03-50490

Installation will require the following tools:

Flat head screwdriver, 6mm and 8mm nut drivers or sockets T20, and T25 torx driver.

Warranty Information available at: <https://afepower.com/contact#warranty>

Emissions Disclaimer: This product is not currently CARB exempt and is not available for purchase in California or for use on any vehicle registered with the California Department of Motor Vehicles.

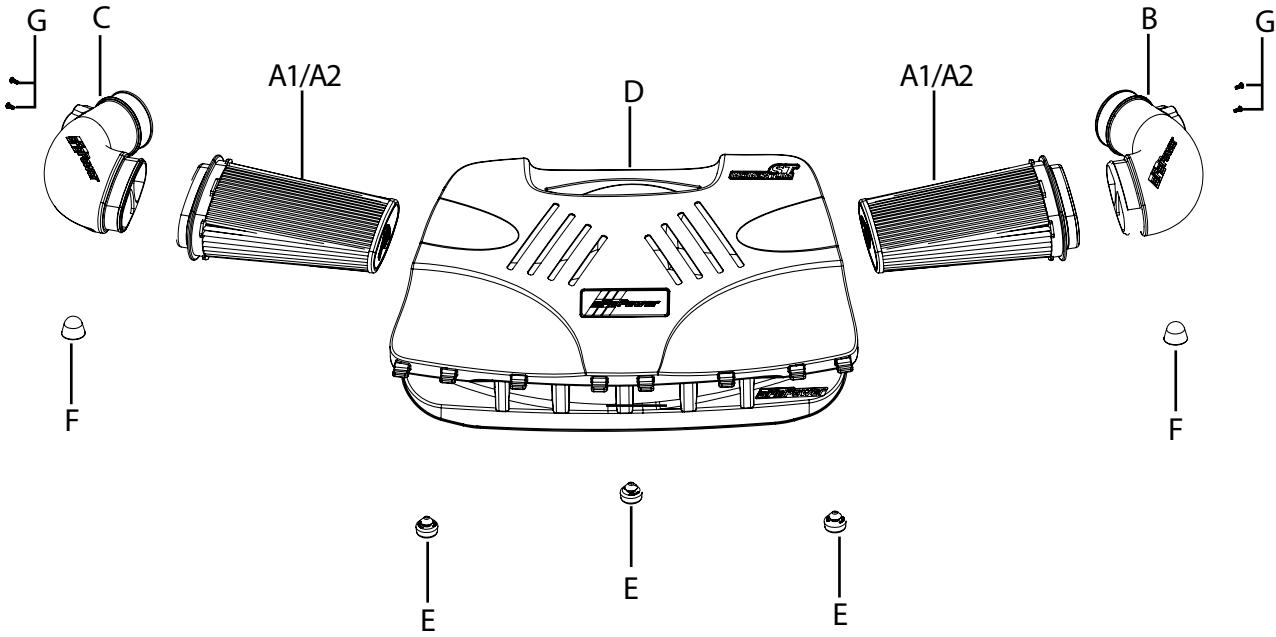



FigureA

Refer to Figure A for Step 1

Step 1: Remove the fresh air duct from the front of the factory airbox, pull upward on the top corners of the duct to release it from the grommets.



FigureB

Refer to Figure B for Steps 2-4

Step 2: Disconnect the Mass Air Flow (MAF) sensors from the driver and passenger sides of the airbox.

Step 3: Loosen the 6mm clamps securing the factory intake tubes and disconnect them from the airbox.

Step 4: Remove the factory airbox from the vehicle.



FigureC

Refer to Figure C for Step 5

Step 5: Install the three (3) provided grommets into the holes on the aFe POWER airbox.



Refer to Figure D for Steps 6

Step 6: Install the aFe POWER airbox in the vehicle, start by sliding the tabs on the front of the airbox into the radiator support then press the rear of the airbox down on the mounting peg.



Refer to Figure E for Steps 7-8

Step 7: Install the air filters in the airbox. Press until you feel or hear all six (6x) of the tabs seat themselves in the housing. Gently pull on the filters to verify is properly seated.

Step 8: Place the two (2) rubber mounts on the factory mounting pegs. (One on Driver side, One on Passenger side)



Figure F

Refer to Figure F for Step 9

Step 9: Transfer the MAF sensors from the factory airbox to the aFe POWER intake tubes and secure them using the provided M4 screws. Make sure to install the driver side sensor on the driver side tube and the passenger side sensor on the passenger side tube.



FigureG

Refer to Figure G for Steps 10-13

- Step 10: Install the aFe POWER tubes, by sliding them into the factory intake tube first, then into the air filter.
- Step 11: Align tubes and filters then tighten all clamps.
- Step 12: Reconnect both MAF sensors.
- Step 13: Verify all connection are secured. Your installation is completed. Thank you for choosing aFe POWER!

NOTE: Check all bolts, clamps, and connectors after 100-200 miles.

Page left blank intentionally

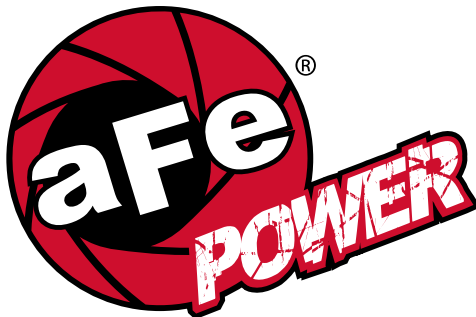

advanced FLOW engineering, inc.
252 Granite Street Corona, CA 92879
<https://afepower.com/contact>