

GT
MOMENTUM

advanced FLOW engineering

Cold Air Intake System

Instruction Manual P/N: 50-70114D / 50-70114R

Make: Toyota

Model: Tundra

Year: 2007-2021

Engine: V8-5.7L w/ Magnuson
Supercharger



- Please read the entire instruction manual before proceeding.
- Ensure all components listed are present.
- If you are missing any of the components, call customer support at 951-493-7185.
- Ensure you have all necessary tools before proceeding.
- Do not attempt to work on your vehicle when the engine is hot.
- Retain factory parts for future use.

Label	Qty.	Description	Part Number
A	1	Air Filter (Pro DRY S) For 50-70114D	21-91072
A	1	Air Filter (Pro 5R) For 50-70114R	24-91072
B	1	Tube	05-5070114B1
C	1	Housing	05-76003B2
D	1	Coupling, Silicone Bellows: 3-1/2"ID x 3"L	05-01743
E	1	Plug	05-01429
F	1	Seal Trim (13.5" Long)	05-01507
G	1	Clamp, T-Bolt (8-5/16"-8-5/8")	03-50267
H	2	Clamp, 56 (3-1/16"-4")	03-50009
J	1	Fitting, 15/32" Barbed	03-50824
K	1	Fitting, 3/16" Barbed	03-50191
M	2	Screw, Torx: M4x.7x8mm	03-50491
N	1	Hose, Silicone 1/2" ID (4.5" Length)	05-01396
P	1	Hose, Silicone 1/2" ID (13" Length)	05-01396

Installation will require the following tools:

8mm Nut Driver, 10 mm Nut Driver, T20 Torx Driver, Pliers or Channel Lock Pliers, Phillips Head Screw Driver, Flat Head Screw Driver, 1/4" Ratchet, 10mm Socket, 16mm wrench or deep socket

Warranty Information available at: <https://afepower.com/contact#warranty>

Emissions Disclaimer: This product is not currently CARB exempt and is not available for purchase in California or for use on any vehicle registered with the California Department of Motor Vehicles.

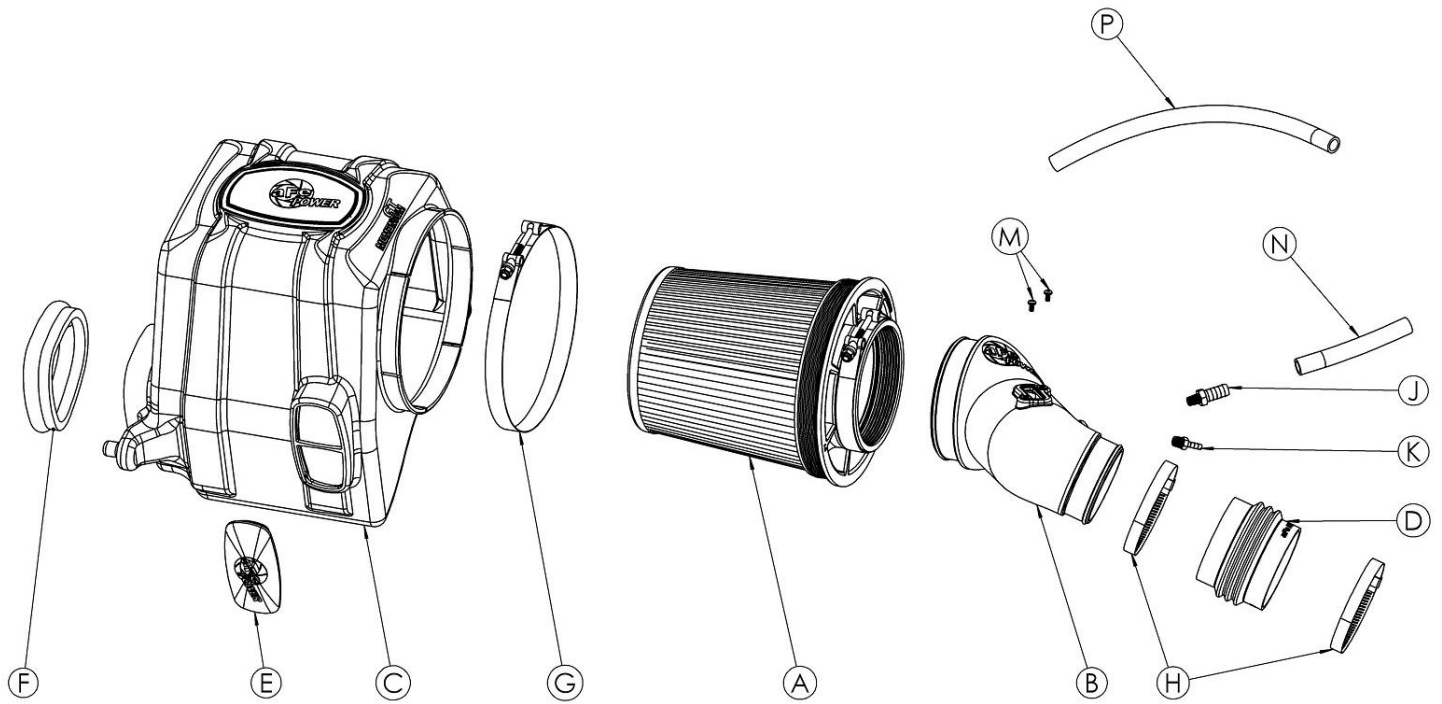

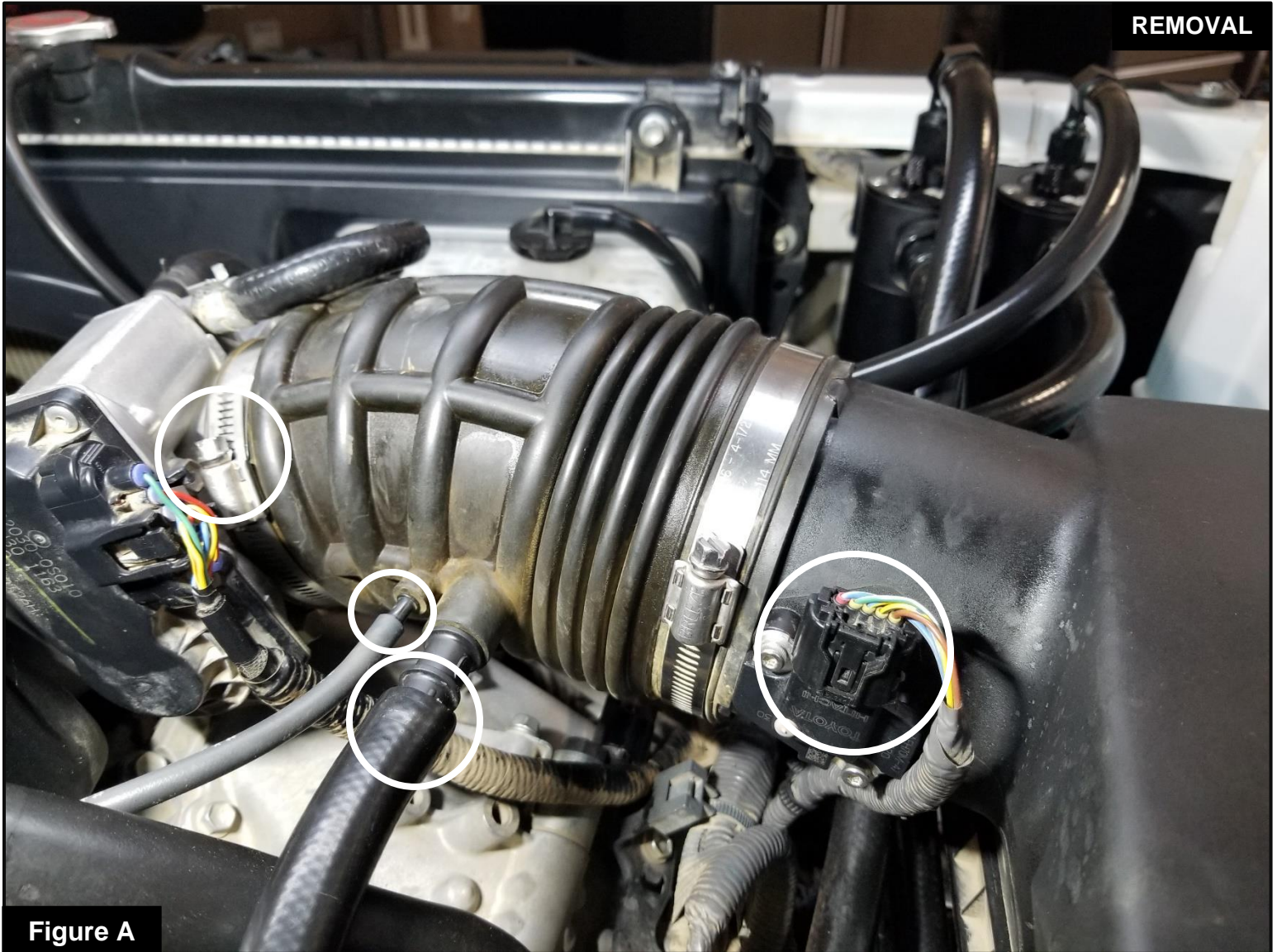
**Figure A****Refer to Figure A for Steps 1-4**

Step 1: Disconnect the Mass Air Flow (MAF) Connector harness from the sensor.

Step 2: Disconnect the smaller vacuum line from the factory tube.

Step 3: Disconnect the crankcase hose from the factory tube.

Step 4: Loosen the clamp on the throttle body.

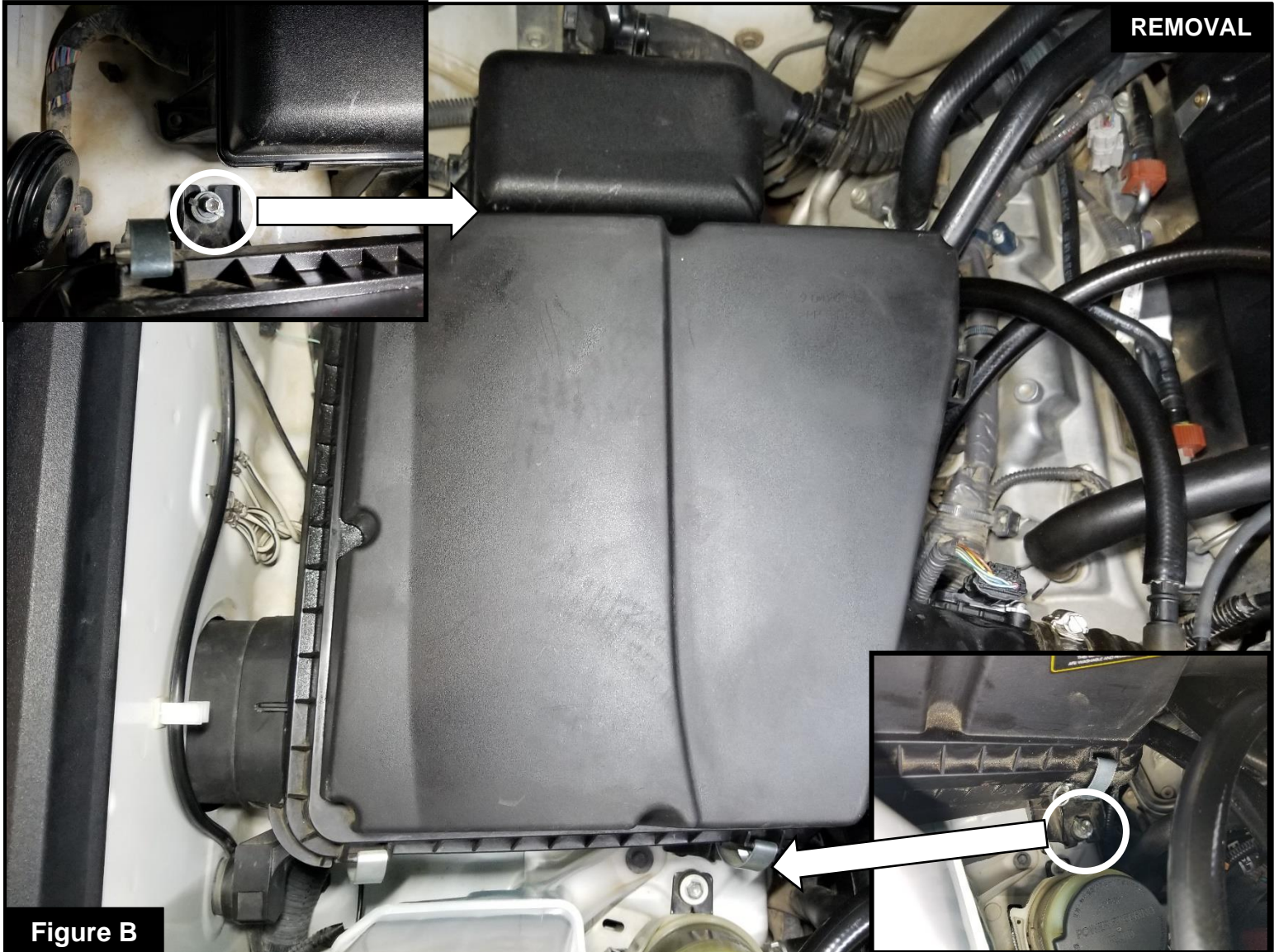

Refer to Figure B for Step 5

Step 5: Remove the two (2) 10mm screws securing the factory housing.



Figure C

Refer to Figure C for Steps 6-7

Step 6: Disconnect the inlet duct from the factory housing.

Step 7: Remove the factory housing and tube from the vehicle.



Figure D

Refer to Figure D for Step 8

Step 8: Collapse the inlet duct and remove it from the vehicle.

**Figure E****Refer to Figure E for Steps 9-10**

Step 9: Using the provided torx screws transfer the MAF sensor to the aFe POWER tube.

Step 10: Install both fittings into the aFe POWER tube as shown. **DO NOT OVER TIGHTEN. SPACE BETWEEN THE NPT FITTING AND THE TUBE IS NORMAL.**



Figure F

Refer to Figure F for Steps 11-12

Step 11: Install the provided seal trim onto the aFe POWER housing inlet as shown.

Step 12: Transfer the rubber grommet from the factory housing to the aFe POWER housing.

**Figure G****Refer to Figure G for Step 13**

Step 13: This kit includes an optional plug to close off the auxiliary air inlet. Install the plug if you wish to only capture cold air from the factory inlet.

- Without the plug installed, the Takeda intake will capture the maximum air available. More airflow offers more power, yet some of this air is picked up from inside the engine compartment and could be warmer, which will affect the performance of the vehicle.
- The plug installed on the housing will block off any hot engine air entering the housing to make sure the coolest air available is directed into the engine. Intake noise will also be reduced using the plug

**Figure H****Refer to Figure H for Steps 14-15**

Step 14: Transfer the rubber grommet and screw from the factory airbox to the aFe POWER housing.

Step 15: Install the aFe POWER housing into the vehicle and tighten the 10mm screws inside the housing from step 5 to secure the aFe POWER housing.

**Figure I****Refer to Figure I for Steps 16-17**

Step 16: Install the air filter into the aFe POWER housing and tighten the large T-bolt clamp on the aFe POWER housing.

Step 17: Slide the smaller T-bolt clamp over the filter flange as shown but do not tighten at this time.

**Figure J****Refer to Figure J for Step 18**

Step 18: Slide the coupling over the throttle body along with both clamps as shown. Tighten only the clamp on the throttle body side at this time.



Refer to Figure K for Steps 19-20

Step 19: With both clamps loose, insert the aFe POWER tube into the coupling then into the air filter.

Step 20: Align the tube and filter then tighten all clamps.

**Figure L****Refer to Figure L for Steps 21-23**

Step 21: Use the 4.5" provided hose to connect to the black fitting on the aFe POWER tube to the T-fitting.

Replace the factory hose from the T-fitting to the passenger side valve cover with the provided 13" silicone hose. Use the factory clamps.

Step 22: Reconnect the vacuum line to the brass fitting on the aFe POWER tube.

Step 23: Reconnect the MAF sensor.



Refer to Figure M for Step 24

INSTALL

Step 24: Make sure that all clamps and connections are secured. Your installation is now complete. Thank you for choosing aFe POWER!

NOTE: Check to ensure that all screws, clamps, and connectors are secured after 100-200 miles.



PAGE LEFT BLANK INTENTIONALLY



PAGE LEFT BLANK INTENTIONALLY



PAGE LEFT BLANK INTENTIONALLY



advanced FLOW engineering, Inc.

Corona, CA 92879

<https://afepower.com/contact>