

advanced FLOW engineering

Cold Air Intake System

Instruction Manual P/N: 51-32642-1B / 54-32642-1B

Make: Ford Model: F-150 Year: 2015-2024 Engine: V6-2.7L (tt) EcoBoost

Make: Ford Model: F-150 Year: 2015-2016 Engine: V6-3.5L (tt) EcoBoost



- Please read the entire instruction manual before proceeding.
- Ensure all components listed are present.
- If you are missing any of the components, call customer support at 951-493-7185.
- Ensure you have all necessary tools before proceeding.
- Do not attempt to work on your vehicle when the engine is hot.
- Retain factory parts for future use.

| Label | Qty. | Description | Part Number |
|-------|------|-------------------------------------|-------------|
| A1 | 1 | Air Filter (Pro DRY S) | 21-91040 |
| A2 | 1 | Air Filter (Pro 5R) | 24-91040 |
| B | 1 | Seal, Trim (23") | 05-00072 |
| C | 1 | Fitting, Air Temp Sensor | 05-01454 |
| D | 1 | Tube | 05-32642B1 |
| E | 1 | Housing | 05-32642B2 |
| F | 1 | Coupling, Silicone Reducer | 05-01331 |
| G | 1 | Coupling, Silicone Hump | 05-01332 |
| H | 2 | Clamp 2-1/2" - 4-1/2" | 03-50006 |
| I | 1 | Clamp 2-13/16" - 3-3/4" | 03-50008 |
| J | 1 | Clamp, 2-5/16" - 3-1/4" | 03-50019 |
| K | 1 | Grommet | 03-50167 |
| L | 2 | M6 (x1x25) screw | 03-50114 |
| M | 2 | M6 Flat Washer | 03-50070 |
| N | 2 | M6 Lock washer | 03-50071 |
| O | 1 | Vent Insert (For V6-3.5L (tt) only) | 05-01405 |

Tools required: 7mm nut driver, 8mm nut driver, 10mm socket & driver, & flat blade screw-driver.

Product covered by one or more of the following patents: 11125150, 11603792, 10648404

Warranty Information available at: <https://afepower.com/contact#warranty>

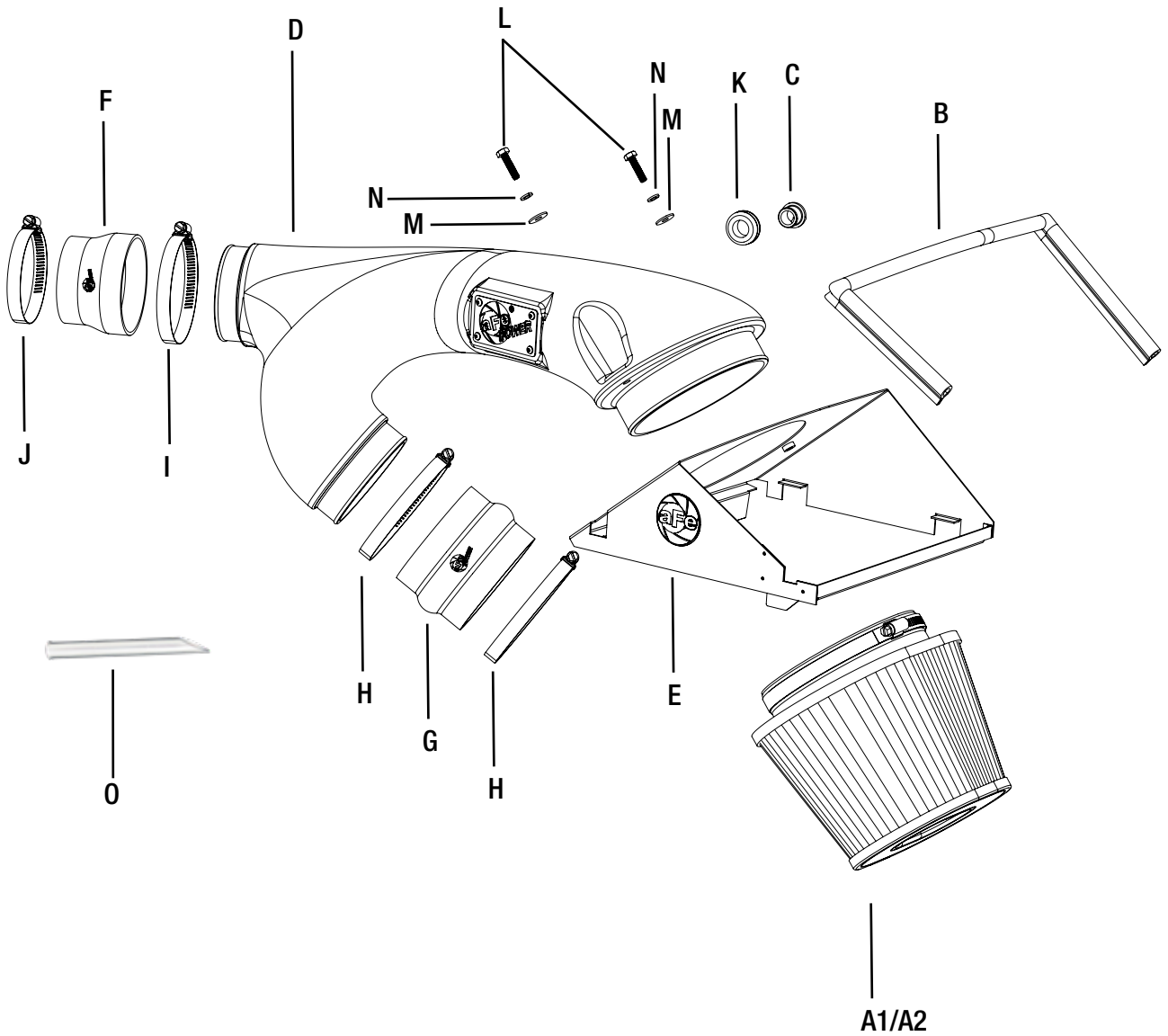

**Figure A****Figure 1****Refer to Figure A for Steps 1-3**

- Step 1: Rotate ① temperature sensor counter clockwise 1/4 quarter turn then pull it out of the tube.
- Step 2: Untighten the three ② clamps on the air intake tube. Pull the tube out of the truck.
- Step 3: Unclip the top of air box and remove the top half of the box and the air filter.



Figure B

Refer to Figure E for Steps 4-5

Step 4: Install the grommet into hole on the back side of the in aFe tube then push the aluminum fitting in it.

Step 5: Install couplings and clamps onto tube ends. Do not tighten any of the clamps yet.

Secure the intake tube to the housing using the provided bolts, lock washers, and flat washers.



Figure C

Refer to Figure C for Steps 6-7

Step 6: Install the air filter onto the tube, align the flat edge with the top of the airbox, and tighten the clamp.

Step 7: Install trim seal onto housing.

INSTALL



Figure D

Refer to Figure D for Steps 8-9

Step 8: Install the complete assembly into the truck by first lining up the tabs on the airbox and then lining up the couplings.

Step 9: Clip the airbox into place.



Figure F

Refer to Figure F for Steps 10-11

Step 10: Secure the temperature sensor into the aluminum fitting by turning clockwise 1/4 turn.

Important: Make sure the plastic tab clips over the ramp on the top of the fitting.

Step 11: Make sure all clamps and screws are tight.

Proceed to the following pages for installation of the vent insert on V6-3.5L (tt) models.

Vent insert installation:



Figure G

Refer to Figure G for Step 12 (For V6-3.5L (tt) only, not necessary on V6-2.7L (tt))

(These procedures should be done with the inlet tubes installed on the engine. It is shown off the vehicle for better illustration.)

Step 12: Locate the o.e. plastic tube feeding the driver's side turbo inlet.



Figure H

Refer to Figure H for Step 13 (For V6-3.5L (tt) only, not necessary on V6-2.7L (tt))

Step 13: Locate the valve cover vent tube that feeds into driver's side turbo inlet. It is not necessary to remove the engine cover.



Figure I

Refer to Figure I for Step 14 (For V6-3.5L (tt) only, not necessary on V6-2.7L (tt))

Step 14: Note the release clip on the vent tube connectors. Apply pressure against the exposed tail and pull vent fitting off of the turbo inlet tube. It is not necessary to disconnect at the valve cover end. There is a sensor and wire harness on this vent tube. Do not damage or remove these components.



Figure J

Refer to Figure J for Step 15 (For V6-3.5L (tt) only, not necessary on V6-2.7L (tt))

Step 15: Insert vent fitting with slash cut facing turbo inlet. It should not be a loose fit. It is direction dependent and must not rotate once installed.



Figure K

Refer to Figure K for Steps 16-17 (For V6-3.5L (tt) only, not necessary on V6-2.7L (tt))

Step 16: Reconnect the vent fitting. It will snap over without having to release the plastic clip.

Pull up slightly to confirm installation.

Step 17: Installation is complete. Any codes can be cleared with a code reader or by disconnecting the battery. You will lose any radio presets with battery disconnection.

If removal of the vent insert is required, it can be pulled out with internal snap ring pliers.

NOTE: *Retighten all connections after approximately 100-200 miles.*

Place the included CARB EO sticker on or near the device on a smooth, clean surface.

EO identification is required to pass the smog inspection.



Page left blank intentionally

Page left blank intentionally

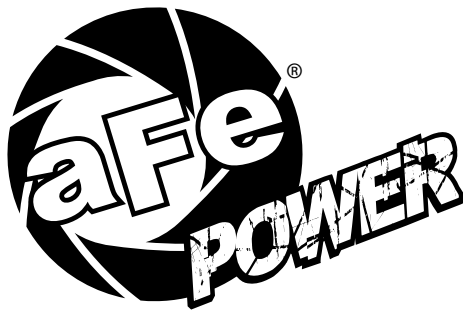

advanced FLOW engineering, inc.

Corona, CA 92879

<https://afepower.com/contact>