

**GT**  
**MOMENTUM**

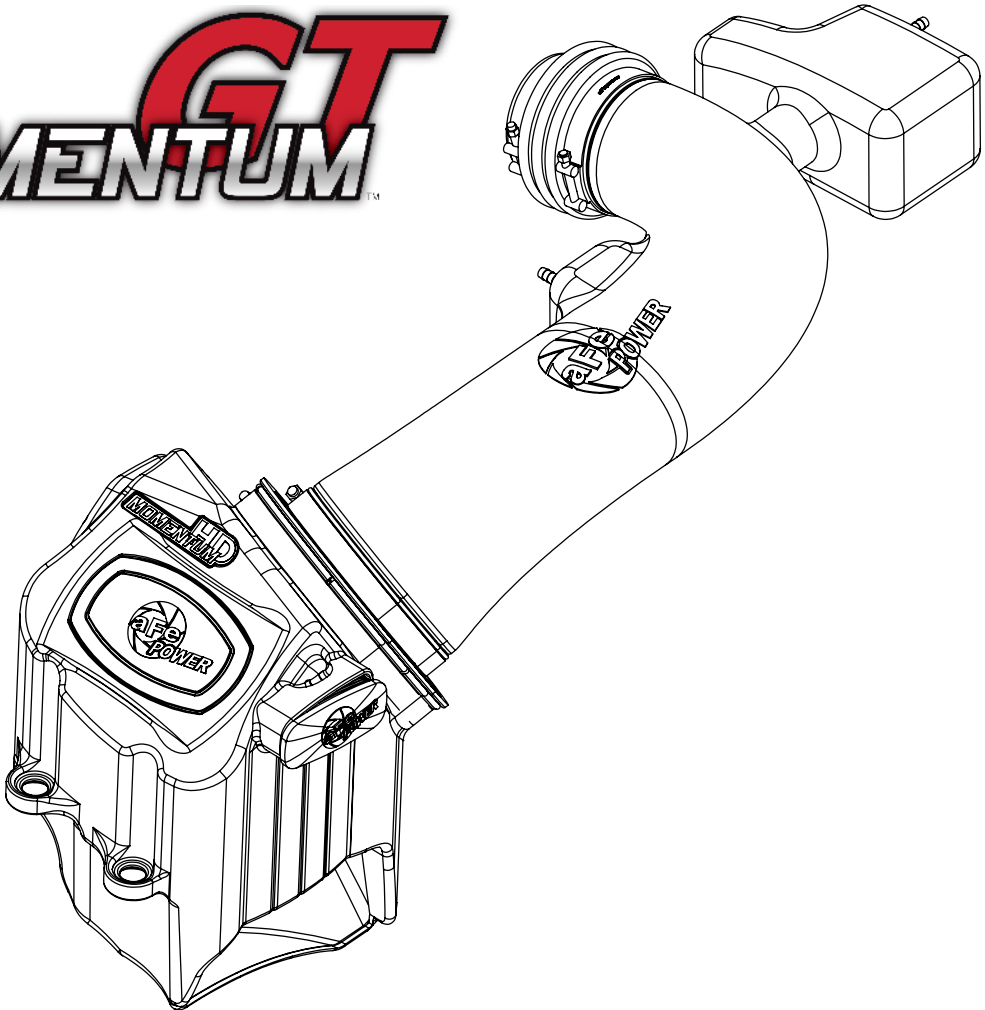

**advanced FLOW engineering** Momentum GT Cold Air Intake System

**Instruction Manual** P/N: 51-73116 / 54-73116 / 75-73116

Make: **Ford** Model: **Super Duty F-250/F-350** Year: **2017-2019** Engine: **V8-6.2L**



- Please read the entire instruction manual before proceeding.
- Ensure all components listed are present.
- If you are missing any of the components, call technical support at 951-493-7100 or e-mail tech@afepower.com.
- Ensure you have all necessary tools before proceeding.
- Do not attempt to work on your vehicle when the engine is hot.
- Disconnect both the negative battery terminal before proceeding.

## Retain factory parts for future use.

Label	Qty.	Description	Part Number
A	1	Pro 5R (Blue Media)	24-91061
A	1	Pro DRY S (Gray Media)	21-91061
A	1	Pro-GUARD 7 (Gold Media)	72-91061
B	1	Tube	05-73116B1
C	1	Housing	05-73006B2
D	1	Plug, Urethane	05-01225
E	1	Coupling, Silicone Bellow	05-01434
F	1	Fitting, Vent	05-01339
G	2	Nipple, Brs Hose: 5/16"	03-50192
J	2	Clamp, Mini #004	03-50097
K	1	Clamp, T-bolt (8-5/16" - 8-5/8")	03-50267
M	1	Clamp, T-bolt (3-9/16" - 3-7/8")	03-50498
N	1	Clamp, T-bolt (4-1/16" - 4-3/8")	03-50262
P	1	Hose, Fuel: 5/16" (9" inches)	05-00112
Q	1	Plug, Hex Socket: 1/8" NPT	03-50410

### Installation will require the following tools:

7mm, 8mm, 10mm, 7/16 nut driver or socket and extension.

**Emissions Disclaimer:** This product is not currently CARB exempt and is not available for purchase in California or for use on any vehicle registered with the California Department of Motor Vehicles.

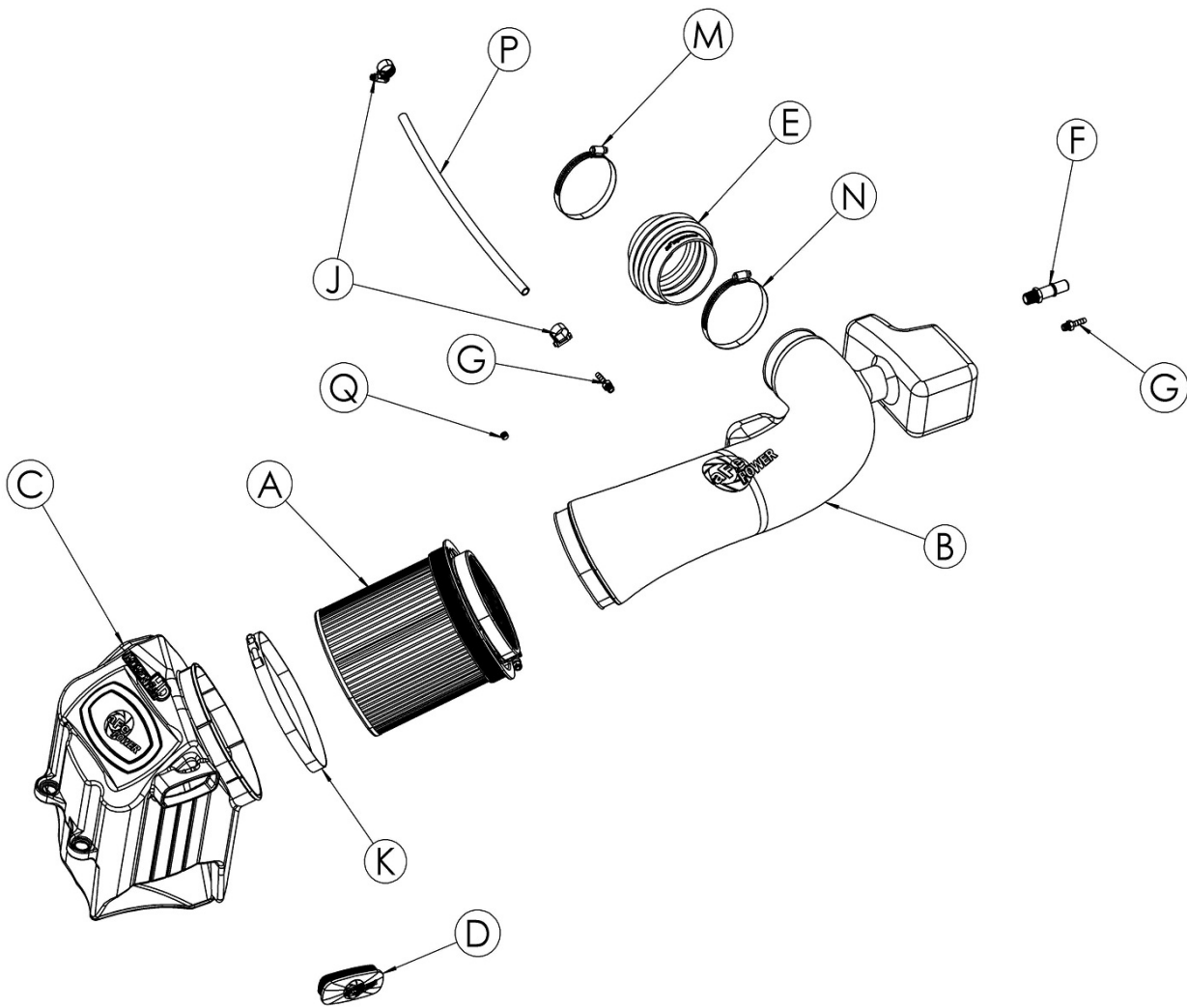



**Refer to Figure A for Step 1**

Step 1: Remove the two (x2) 8mm bolts securing the factory filter housing, and loosen the two (x2) clamps on the factory tube.



Figure B

**Refer to Figure B for Step 2**

Step 2: Remove the factory airbox, pulling in an upward motion.



### **Refer to Figure C for Step 3**

Step 3: Disconnect the three (x3) vent hoses from the factory tube, making sure the passenger side hose is disconnected at the white plastic tee fitting.

**NOTE: Some vehicles do not have a passenger side hose.**



Figure D

**Refer to Figure D for Step 4**

Step 4: Remove the factory tube from the vehicle by pulling upward and away from the throttle body.

**NOTE:** Make sure the factory tube mounting grommets stayed in place while pulling out the tube.



Figure E

**Refer to Figure E for Steps 5-6**

Step 5: Remove the factory grommets from the factory airbox and install on the Momentum GT housing.

Step 6: Slide the filter into the housing and install provided T-bolt clamps. Tighten only the larger T-bolt clamp.





Figure F

**Refer to Figure F for Step 7**

Step 7: Install the Momentum GT housing into the vehicle by pushing it in to the factory grommet.

**Figure G****Refer to Figure G for Steps 8-9**

Step 8: Install coupling and T-bolt clamps onto the small end of the tube. Do not tighten clamps.

Step 9: Install the two (x2) supplied brass fittings, and the one (x1) aluminum fitting on to the tube. Apply some of the provided threadlocker to guarantee a perfect seal. If your vehicle does not have the passenger side hose, close off the passenger side insert on the tube using the provided 1/8" NPT plug.



Figure H

### **Refer to Figure H for Steps 10-13**

Step 10: Install Momentum GT tube by first sliding the coupling over the throttle body. Connect the other end to the air filter.

Step 11: Tighten all clamps.

Step 12: Install provided hose onto the the passenger side brass fitting and white plastic tee fitting. Secure ends with the two (x2) provided mini clamps. This step can be ignored if your vehicle does not have a passenger side hose.

Step 13: Reinstall the factory two (x2) 8mm bolts removed in Step 1 securing the airbox.



Figure 1

### **Refer to Figure 1 for Steps 14-16**

Step 14: If you have purchased the aFe air scoop (P/N: 54-73006-S ), install it referring to its install instruction sheet.

Step 15: If you don't have the air scoop, you have the option to close off the extra air inlet with the supplied plug or to keep it open.

- Without the plug installed, the aFe POWER intake will capture the maximum air available. More airflow offers more power. Yet some of this air is picked up from inside the engine compartment and could be warmer air. Warmer air will affect the performance of the vehicle.
- The plug installed on the housing will block off any hot engine air entering the housing and make sure the coolest air available is directed into the engine. It will also reduce the noise of the intake.

Step 16: Verify all connections are secured. The installation is now complete. Thank you for choosing aFe POWER!

**NOTE: Check all clamps, and connectors after 100-200 miles.**

Page left blank intentionally

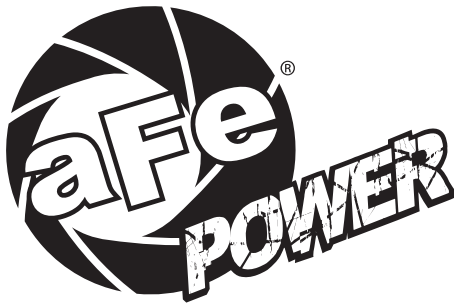

**advanced FLOW engineering, inc.**  
252 Granite Street Corona, CA 92879  
TEL: 951.493.7100 • TECH: 951.493.7134  
E-Mail: [Tech@aFepower.com](mailto:Tech@aFepower.com)