

**advanced FLOW engineering**

**Instruction Manual P/N: 51-74202-1 / 54-74202-1**

---

Make: Chevrolet    Model: Corvette Z06 (C7)    Year: 2015-2019    Engine: V8-6.2L (sc)



- Please read the entire instruction manual before proceeding.
- Ensure all components listed are present.
- If you are missing any of the components, call customer support at 951-493-7185.
- Ensure you have all necessary tools before proceeding.
- Do not attempt to work on your vehicle when the engine is hot.
- Retain factory parts for future use.

Label	Qty.	Description	Part Number
A1	1	Air Filter (Pro DRY S) For 51-74202-1	21-90088
A2	1	Air Filter (Pro 5R) For 54-74202-1	24-90088
B	1	Tube	05-74202B1
C	1	Housing	05-74202B2
D	2	Screw, Torx T20 M4 x .7x8	03-50491
E	2	Clamp, T-Bolt (3-3/4 - 4-1/16)	03-50265
F	1	Vent Fitting	05-01692
G	1	Coupling, Silicone Hump	05-01375
H	15"	Hose, Coolant 3/8" ID	05-01357
I	2	Mini Clamp	03-50025
J	1	Cable Tie	05-60167
K	2	Spacer	05-01207

Tools needed: 7mm, 8mm, 10mm and 7/16 Socket or nut driver, Ratchet and extension, flat head screw driver, razor blade, & Torx T20 Driver.

Warranty Information available at: <https://afepower.com/contact#warranty>

Note: Legal in California for use on race vehicles only. The use of this device on vehicles used on public streets or highways is strictly prohibited in California and others states that have adopted California emission regulations.

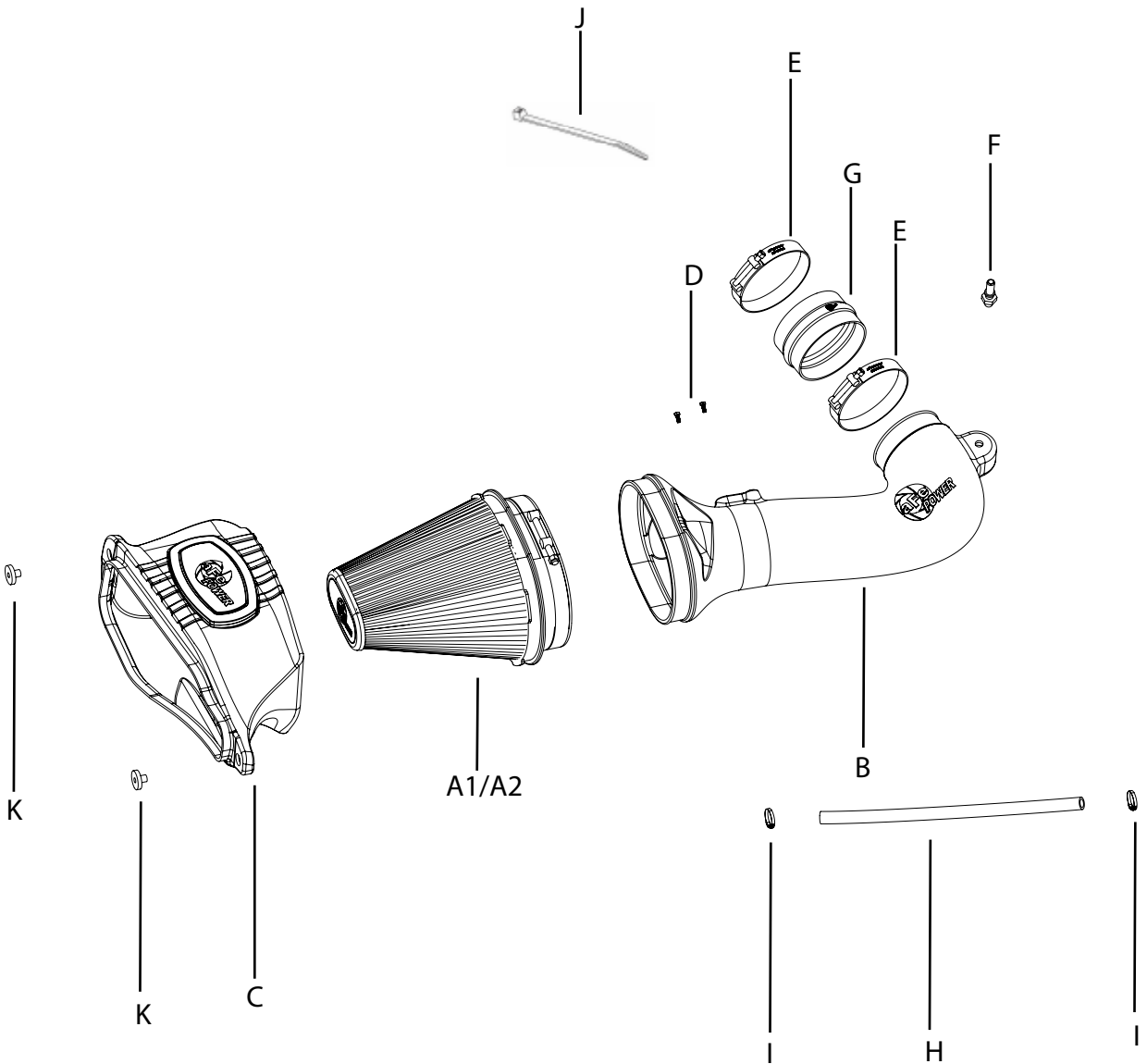

**FigureA**

Refer to Figure A for Step 1

Step 1: Remove the radiator air outlet channel by removing the four screws securing it with a 7mm socket or nut driver.



FigureB

Refer to Figure B for Steps 2-3

Step 2: Disconnect the Mass Air Flow (MAF) Sensor harness.

Step 3: Loosen the clamps at the throttle body and at the housing. Disconnect the vent hose then remove the factory intake tube out of the vehicle.



**FigureC**

Refer to Figure C for Step 4

Step 4: Remove the two 10mm screws holding the factory intake box and pull it out of the mounting grommet then out of the vehicle.



Figure D

### Refer to Figure D for Steps 5-6

Step 5: Transfer the three mounting grommet from the factory air box to the aFe Housing and install the furnished aluminum spacer on the two grommets.

Step 6: Slide the filter into the housing and push it in until it locks into place.



Figure E

Refer to Figure E for Step 7

Step 7: Install the aFe filter/housing assembly into the vehicle. Push it on the factory stud and secure it using the two factory 10 mm screws removed at step 4.





Figure F

Refer to Figure F for Steps 8-9

Step 8: Remove the MAF sensor from the factory air box. Install it on the aFe tube using factory O-ring and supplied m4 screws.

Step 9: Screw the provided vent fitting into the aFe tube. This is a NPT fitting. The small gap between the tube and the hex is normal.



Figure G

Refer to Figure G for Steps 10-14

Step 10: Install the silicone coupling over the throttle body.

Step 11: Install the aFe tube into the vehicle. Slide the tube first into the filter then the coupling on the throttle body.

Step 12: Align the tube correctly then install T-bolt clamps over coupling. You may need to open the T-bolt clamps by removing the nut completely. Then install it around the coupling and close it by re-installing the nut. Tighten all clamps.

Step 13: Reconnect the MAF sensor.

Step 14: Connect the vent hose onto the aluminum fitting.

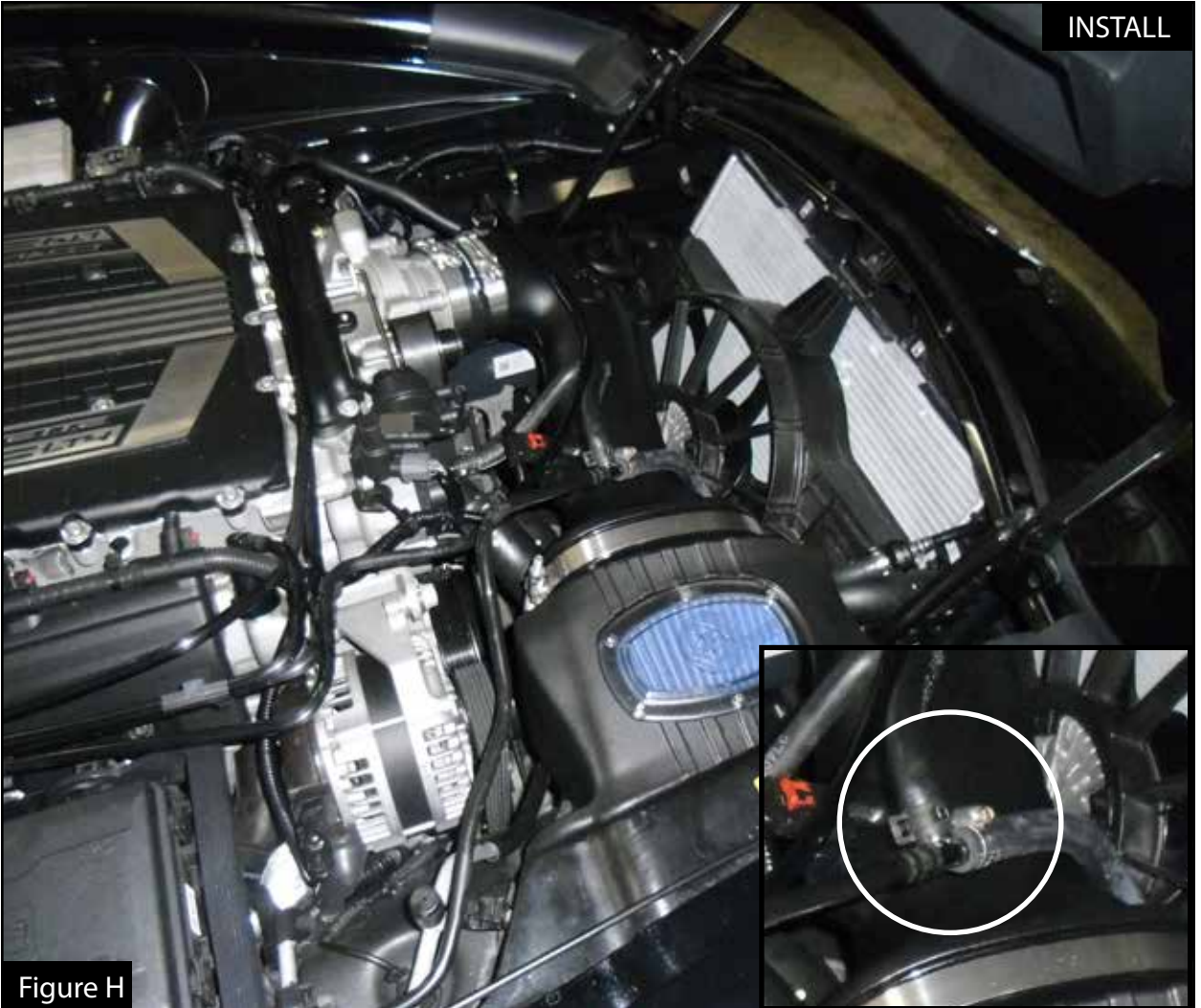

Figure H

Refer to Figure H for Steps 15-16

**Make sure engine is cold before disconnecting the coolant line.**

Step 15: The coolant line needs to be re-routed to make clearance for the hood vent. Locate the short hard plastic coolant line between the check valve and the T-fitting. Put a shop towel under it to catch the coolant excess when disconnected.

Step 16: With a sharp blade, slice open the hard plastic coolant line on both sides and remove it.



Figure I

Refer to Figure I for Steps 17-19

Step 17: Replace the hard plastic line with the furnished hose. Install mini clamps on both ends to secure it.

Step 18: Route the hose over the tube like shown in picture. It will sit under the radiator air outlet

Make sure it doesn't kink or put pressure on the MAF sensor. If necessary you can rotate the factory wing clamp.

Step 19: Use the furnished cable tie to secure the coolant line to the vent hose and prevent any contact with the serpentine belt.





Figure J

Refer to Figure J for Steps 20-21

Step 20: Re-install the factory radiator air outlet.

Step 21: Make sure all clamps and connections are secured. Your installation is now completed.

\*Verify all connections are secure 100-200 miles after installation





PAGE LEFT BLANK INTENTIONALLY

PAGE LEFT BLANK INTENTIONALLY



**advanced FLOW engineering, inc.**  
252 Granite Street Corona, CA 92879  
<https://afepower.com/contact>