

**MOMENTUM** *GT*

*advanced FLOW engineering*

Cold Air Intake System

**Instruction Manual** P/N: 51-76003-R

Make: Toyota

Model: Tundra

Year: 2007-2021

Engine: V8-5.7L



- Please read the entire instruction manual before proceeding.
- Ensure all components listed are present.
- If you are missing any of the components, call customer support at 951-493-7185.
- Ensure you have all necessary tools before proceeding.
- Do not attempt to work on your vehicle when the engine is hot.
- Retain factory parts for future use.

Label	Qty.	Description	Part Number
A	1	Air Filter (Pro DRY S)	21-91072
B	1	Tube	05-76003R1
C	1	Housing	05-76003R2
D	1	Coupling, Straight: 3-1/2"ID x 2"L	05-01280
E	1	Plug	05-01429
F	1	Seal Trim (15" Long)	05-01507
G	1	Hose, Fuel 1/2" ID (18" Long)	05-00027
H	2	Clamp, 56 (3-1/16"-4")	03-50009
J	1	Clamp, T-Bolt (8-5/16"-8-5/8")	03-50267
K	1	Fitting, Hose 3/16" IDx1/8 NPT	03-50191
M	2	Screw, Torx: M4x.7x8mm	03-50491

**Installation will require the following tools:**

8mm Nut Driver, 10 mm Nut Driver, T20 Torx Driver, Pliers or Channel Lock Pliers, Phillips Head Screw Driver, Flat Head Screw Driver, 1/4" Ratchet, 10mm Socket, 16mm wrench or deep socket

**NOTE:** All installation photos are of the black version of this kit. All steps are the same.

Warranty Information available at: <https://afepower.com/contact#warranty>

**Emissions Disclaimer:** This product is not currently CARB exempt and is not available for purchase in California or for use on any vehicle registered with the California Department of Motor Vehicles.

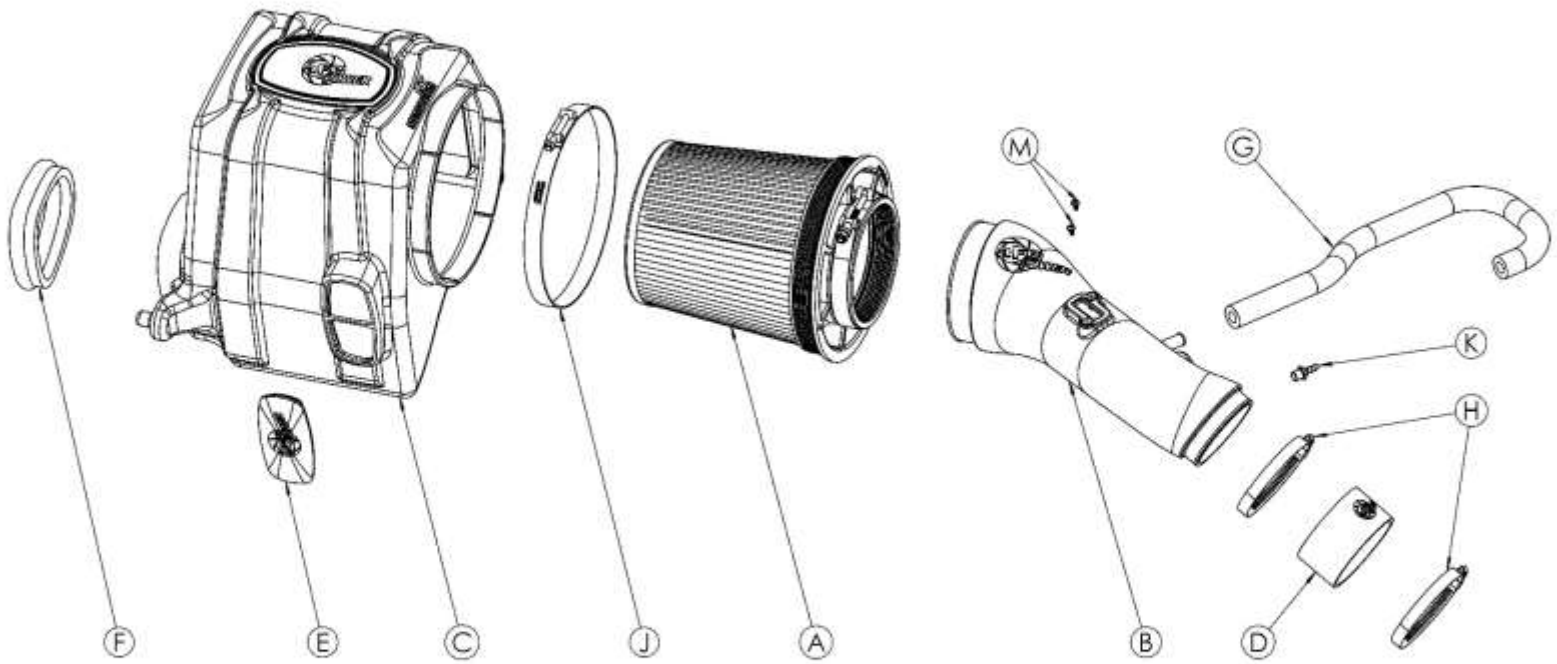



Figure A

**Refer to Figure A for Step 1**

Step 1: Remove the engine cover by grasping both sides and carefully lifting upward.





**Figure B**

**Refer to Figure B for Step 2**

Step 2: Unclip the wire harness tab from the factory airbox.



**Figure C**

**Refer to Figure C for Steps 3-8**

- Step 3: Disconnect the mass air flow (MAF) sensor harness (1).
- Step 4: Disconnect the vacuum line (smaller tube) from the factory intake tube (2).
- Step 5: Remove the crank case vent (CCV) hose. \*Optional save the 2 factory spring clips for use later (3).
- Step 6: Using a 10 mm nut driver, loosen both bolts securing the housing to the fender well (4).
- Step 7: With 10mm nut driver, loosen hose clamp on throttle body (5).
- Step 8: Lift and remove factory intake system out of the vehicle.



**Figure D****Refer to Figure D for Steps 9-10**

Step 9: Remove the MAF sensor from the factory intake and transfer it to the aFe intake tube. Secure using the two provided torx screws.

Step 10: Install the brass hose fitting onto the aFe intake tube and tighten using a 16mm wrench or deep socket. **DO NOT OVER TIGHTEN. SPACE BETWEEN THE 16MM HEX AND TUBE IS NORMAL.**

**Figure E****Refer to Figure E for Step 11**

Step 11: Remove and transfer the two rubber isolation mounts, and the large rubber grommet to aFe Momentum housing (6).





Figure F

**Refer to Figure F for Step 12**

Step 12: Install the provided seal trim onto the aFe housing inlet as shown.

**Figure G****Refer to Figure G for Step 13**

Step 13: Before installing the housing, insert the captive bolts into the rubber grommets (7) from the inside as shown.

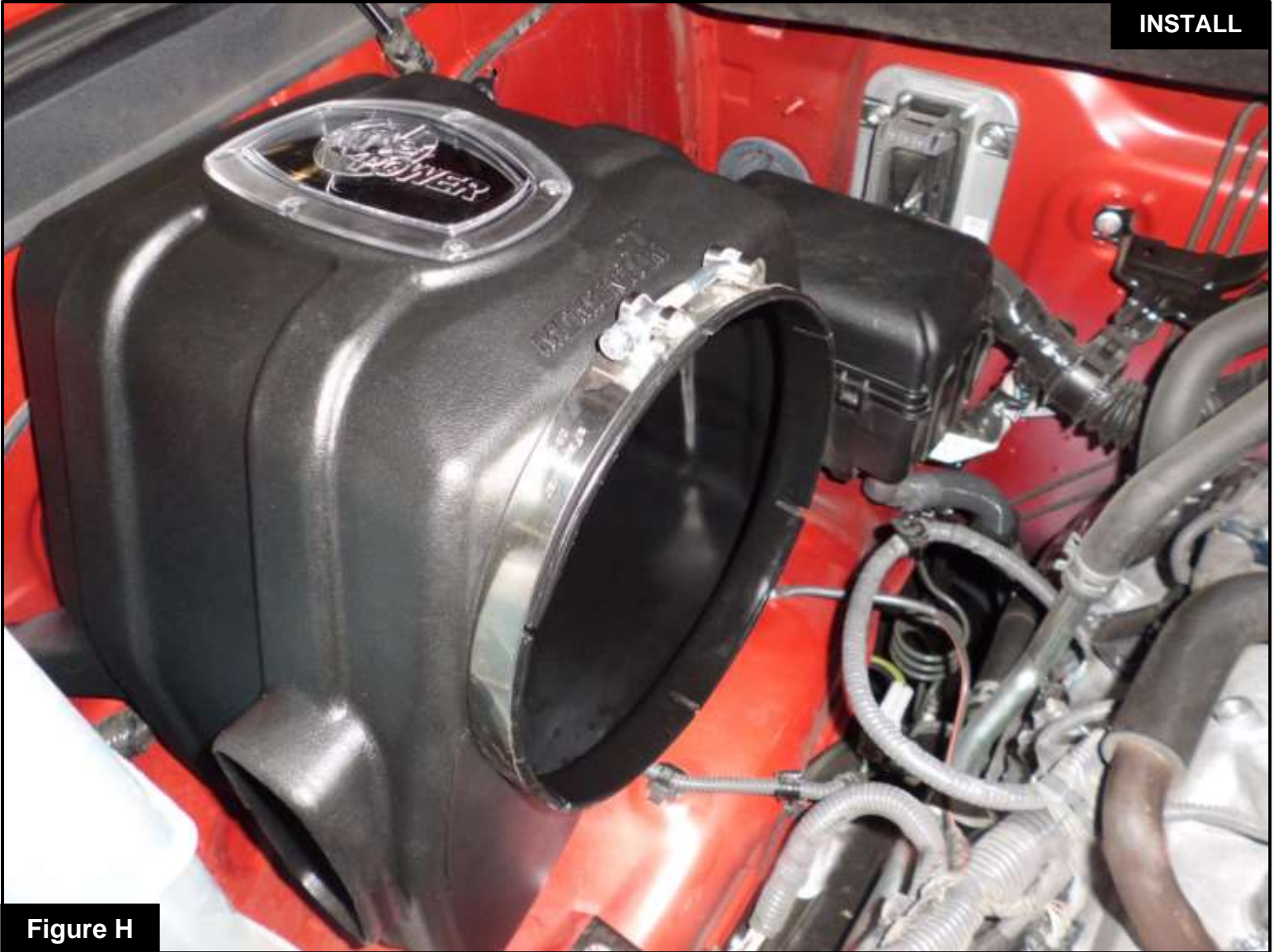
**Figure H****Refer to Figure H for Steps 14-15**

Step 14: Install the aFe Momentum housing as shown. Tighten the bolts on the inside of the housing using a 1/4" ratchet with 10mm socket.

Step 15: Install the large t-bolt clamp as shown but do not tighten at this time.



**Figure I****Refer to Figure I for Steps 16-18**

Step 16: Install the air filter into the housing and tighten the large t-bolt clamp (8).

Step 17: Slide the smaller t-bolt clamp over the filter flange as shown but do not tighten at this time (9).

Step 18: Slide the straight coupling over the throttle body along with both clamps as shown (10). Do not tighten them at this time.



Figure J

**Refer to Figure J for Step 19**

Step 19: Insert the aFe tube into the Momentum filter as shown and rotate it forward to line up with the throttle body.



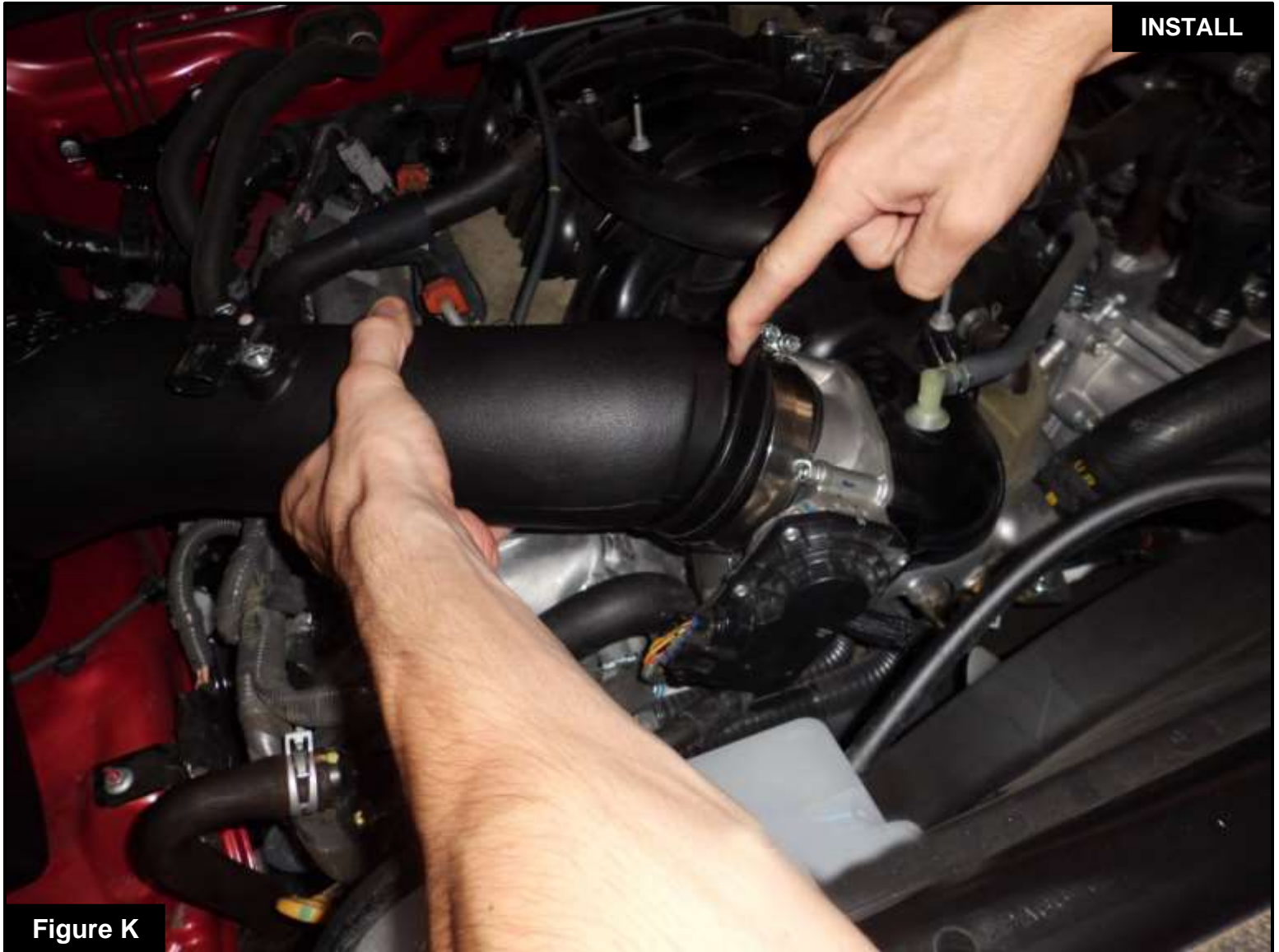

Figure K

**Refer to Figure K for Steps 20-21**

Step 20: With both clamps loose, insert the aFe tube into the straight coupling as shown.

Step 21: Tighten both band clamps on the throttle body and the small t-bolt clamp on the filter.



**Figure L****Refer to Figure L for Steps 22-24**

Step 22: Slip metal hose clips over provided hose and install as shown (11).

Step 23: Connect the vacuum line to the brass fitting on the aFe tube (12).

Step 24: Reconnect the MAF sensor as shown (13).



Figure M

**Refer to Figure M for Steps 19-20**

Step 25: Reinstall the engine cover. Your installation is now complete!

Step 26: (Optional) install the plug onto the side of the housing.



PAGE LEFT BLANK INTENTIONALLY





PAGE LEFT BLANK INTENTIONALLY



PAGE LEFT BLANK INTENTIONALLY



***advanced FLOW engineering, Inc.***

Corona, CA 92879

<https://afepower.com/contact>