



INSTALLATION INSTRUCTIONS

Cat-Back Exhaust

MAKE: GM
MODEL: Silverado/ Sierra 1500
YEAR: 2014-2019
ENGINE: V6-4.3L / V8-5.3L

49-34132-P
 49-34132-B

Note: Fits only CC/SB & CC/LB

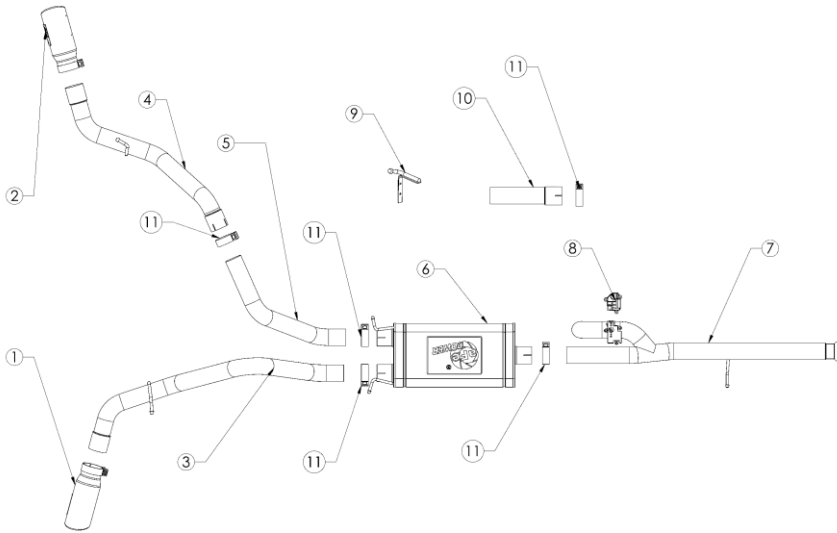

ORDERING REPLACEMENT TIPS?

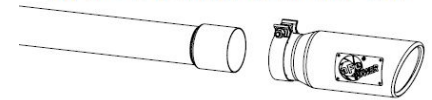

3 1/2" USE: 49T35451/49T35452

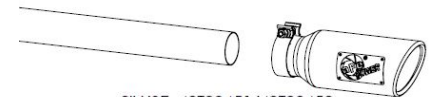

3" USE: 49T30451/49T30452

Item	Description	Part Number	Quantity
1	Tip 3-1/2 In x 4-1/2 Out x 12L Bolt-On Blk	49T30451-B12	1
1	Tip 3-1/2 In x 4-1/2 Out x 12L Bolt-On Pol	49T30451-B12	1
2	Tip 3-1/2 In x 4-1/2 Out x 12L Bolt-On Blk	49T30452-B12	1
2	Tip 3-1/2 In x 4-1/2 Out x 12L Bolt-On Pol	49T30452-B12	1
3	S/A Tube, Right Tail-Pipe: 3" Dia	05-245072	1
4	S/A Tube, Left Tail-Pipe: 3" Dia	05-245074	1
5	S/A Tube, Left Over-Axle: 3" Dia	05-245073	1
6	S/A Muffler Assembly Black	05-245201	1
7	S/A Tube Muffler Bypass Assembly	05-245064	1
8	Motor, Exhaust Valve: 12 Volt	05-70042	1
9	S/A Bracket Hanger	05-46154	1
10	S/A Extension Pipe	05-145072	1
11	Clamp, Band: 3"	05-41055	5
12	Controller, Exhaust Valve	05-70041	1

aFe POWER recommends professional installation on this product. Thoroughly inspect the aFe POWER exhaust system to make sure there is no damage from shipping (if damage is noted, immediately contact aFe POWER customer service). Allow time for your vehicle to cool down prior to installation. When working on your vehicle proceed with caution. Wear protective safety equipment; eye goggles and gloves to ensure a safe installation.

Install band clamps to proper torque specifications of 40-45 ft-lb.



INSTALLATION INSTRUCTIONS

MAKE: GM
MODEL: Silverado/ Sierra 1500
YEAR: 2014-2019
ENGINE: V6-4.3L / V8-5.3L

Cat-Back Exhaust

49-34132-P

49-34132-B

Note: Fits only CC/SB & CC/LB

1. **(Read instructions prior to installation.)** It is recommended to not fully tighten the exhaust until it has been fully installed. Leave loose for adjustability.
2. Secure vehicle on jack stands (refer to your manual for specified jack stand positions).
3. For faster installation, spread out the parts of the exhaust alongside your vehicle as shown in the diagram above.
4. Secure the stock exhaust with jack/stands.
5. Remove the stock exhaust. Take caution not to damage the factory front flange bolts and isolation mounts as they will be reused.

6. Install provided x1 Motor to the valve motor mount using the provided x3 bolts and spring clip.
Refer to FIG 1 Below.

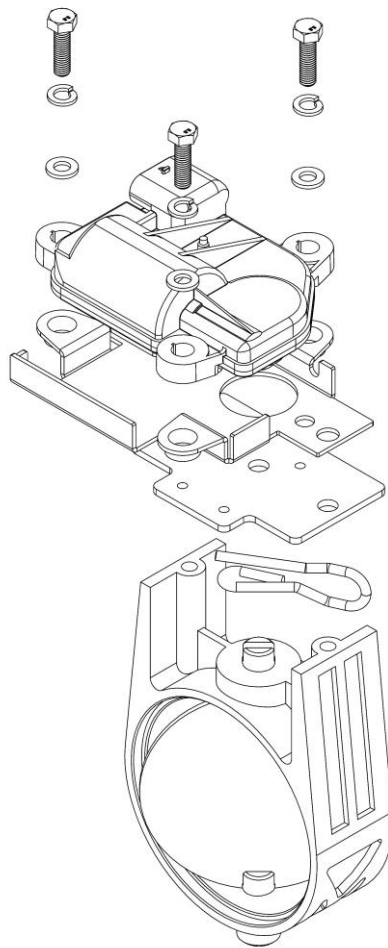

1



INSTALLATION INSTRUCTIONS

Cat-Back Exhaust

MAKE: GM
MODEL: Silverado/ Sierra 1500
YEAR: 2014-2019
ENGINE: V6-4.3L / V8-5.3L

49-34132-P
49-34132-B

Note: Fits only CC/SB & CC/LB

7. Install the flared muffler bypass assembly (this will require reusing the original OE band clamp). Release the locking tab with a small screwdriver and place OE band clamp over front pipe but do not fully tighten.

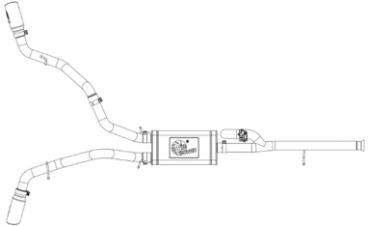
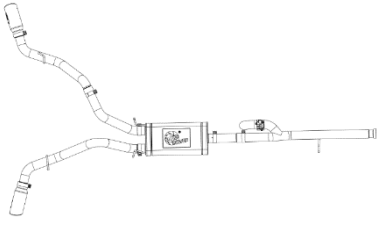
Cab Configuration:	Bed Configuration:	Wheelbase:	Extension Pipe Needed?	
Crew Cab	Short Bed (5.75 ft Bed)	143.5"	NO	
Crew Cab	Long Bed (6.5 ft Bed)	153.5"	YES	

8. Slide the front part of the muffler into the rear of the muffler bypass assembly or extension pipe depending on wheelbase. Then slip rear hangers of the muffler into the OE rubber isolation mounts.
9. Install the "Right" Passenger side tail pipe first, but do not fully tighten.

10. Now install the hanger bracket included with the kit. As shown on **FIG 2** and **FIG 3**.

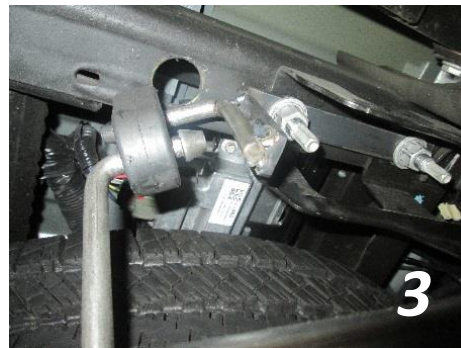

11. Unbolt the OE nuts & bolt using a 19mm deep socket on the bottom side and 19mm wrench on the top fully tighten the hanger bracket to the frame using the OE nuts and bolts.
12. Next install the Over-Axle, do not fully tighten the band clamp.
13. Now slip the Left- Tailpipe into the Over-Axle tube, then slide the hanger into the hanger bracket and rubber isolation mount provided. Do not fully tighten down band clamp.
14. Install both tips onto the tailpipes. Adjust the tips to your desired position. Do not fully tighten the tips.
15. Position and align the entire exhaust system, now begin to fully tighten down all band clamps and bolts starting from the front flange and working your way back to the rear tailpipes and ending at the tips.



INSTALLATION INSTRUCTIONS

MAKE: GM
MODEL: Silverado/ Sierra 1500
YEAR: 2014-2019
ENGINE: V6-4.3L / V8-5.3L

Cat-Back Exhaust

49-34132-P

49-34132-B

Note: Fits only CC/SB & CC/LB

16. If needed, zip ties are included with your kit to create additional clearances for the Left Tailpipe axle breather & brake hoses.

Note: You will need at least 1.5" of clearance from your spare tire and the left side of the exhaust. If you need additional clearance loosen your spare tire and move it away from the exhaust until you have the required clearance, then tighten spare tire back up

17. Run the remaining wire harness inside the frame towards the engine compartment and exit behind the front passenger tire as shown in **FIG 4** and **FIG 5**. Secure using supplied zip ties.



18. In the engine compartment zip tie the control box along the wire harness next to the battery. Run the wire ring terminals to the battery and run the rest of the wire down the back of the firewall to meet the rest of the wire harness. Use provided zip ties to secure the wire. **Refer to FIG 6 and FIG 7**



19. Connect the wire harness together and tuck the remaining wire into the frame. Organize any other loose wires and secure with remaining zip ties.
20. Ensure that all the components of the aFe POWER exhaust system are aligned and are at a safe clearance from all wires, hoses, brake lines, body parts, and tires.
21. Start from the front of the aFe POWER exhaust system and evenly tighten all clamps and fasteners.
22. Start the vehicle and check for any leaks. If any leaks are found, determine cause and repair as necessary.
23. Remove vehicle from jacks stands.
24. It is recommended to re-tighten all clamps and hardware after 50-100 miles.